

# WP 5000

ТЕХНИЧЕСКИ КАТАЛОГ

TECHNICAL CATALOGUE TECHNISCHER KATALOG CATALOG TEHNIC

**Съдържание**

**Contents**

**Inhalt**

**Continut**

<b>5 - камерна система</b> 5-chamber system / 5-Kammer System / Sistem de 5 camere	1 - 8
<b>Монтажи</b> Assemblies / Montageschemas / Montaje	9 - 20
<b>Схема за водоотливане</b> Drainage diagram / Abwasserungsschema / Schema pentru scurgere apa	21
<b>Фрезоване</b> Milling / Frasen / Realizare	22
<b>Схеми</b> Montageschema / Scheme / Schema	23-25
<b>Усилители</b> Reinforced profiles / Verstaerkungsprofile / Armature	26 - 27
<b>Определяне на инерционен момент</b> Calculation of the moment of inertia/ Traegheitsmomentberechnungsformel Calcularea momentului inert necesar	28
<b>Формули</b> Formulas / Formeln / Formule	29 - 30
<b>Профили с ламинирано покритие. Арки</b> Profile mit laminiertem Beschlag / Profiles with polish cover / Profile laminate Bogen / Arches / Arcade	31

**ТЕХНИЧЕСКИ КАТАЛОГ**

**PVC СИСТЕМИ**

**TECHNICAL CATALOGUE  
PVC SYSTEMS**

**TECHNISCHER KATALOG  
PVC SYSTEME**

**CATALOG TEHNIC  
SISTEME PVC**



# 5 - КАМЕРА СИСТЕМА

5-chamber system / 5-Kammer System/  
Sistem de 5 camere

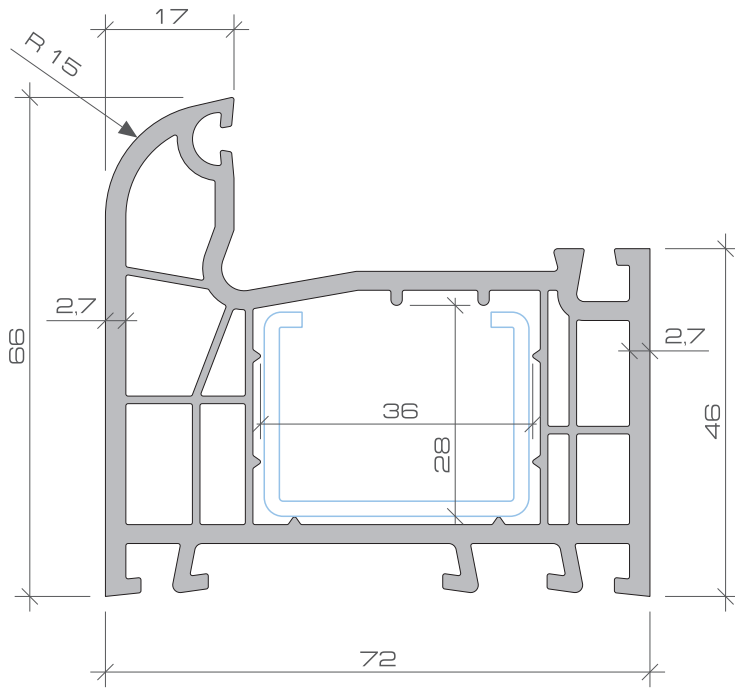

КАСА  
Rahmenprofil  
Frame profile  
Profil toc

WP 5001

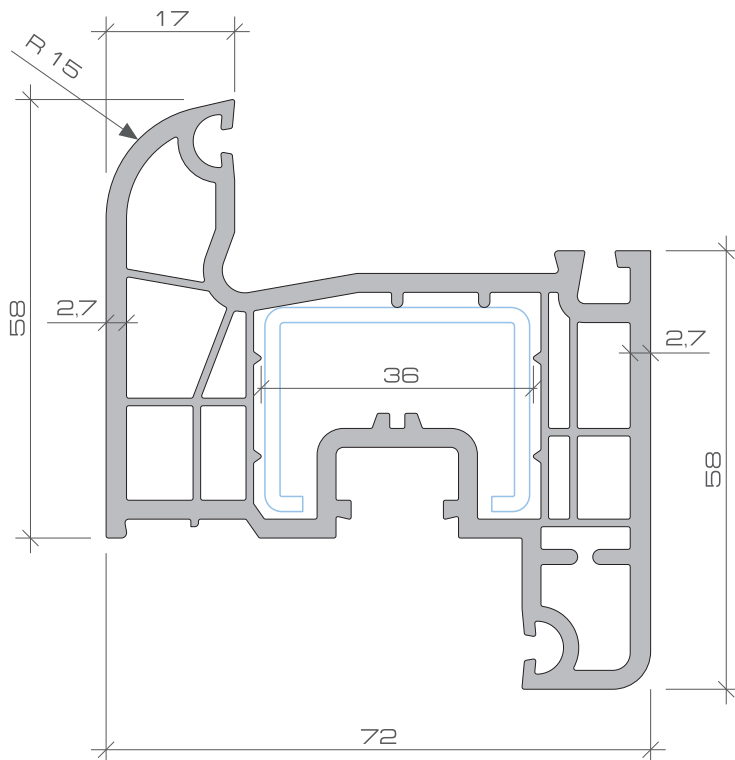

КРИЛО  
Fluegelprofil  
Sash profile  
Profil anpa

WP 5002

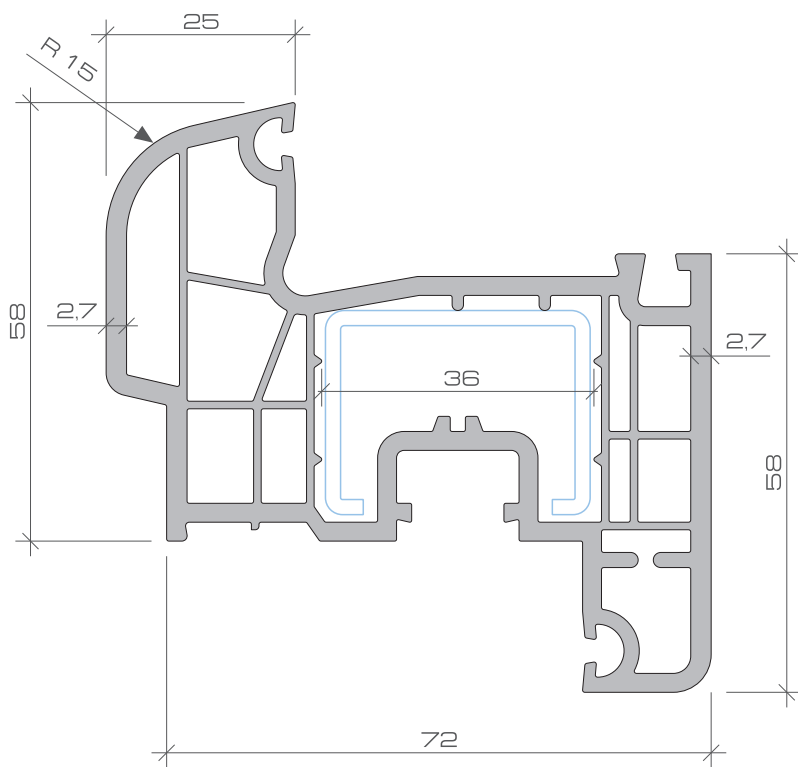

КРИЛО  
 Fluegelprofil  
 Sash profile  
 Profil aripa  
 WP 5010

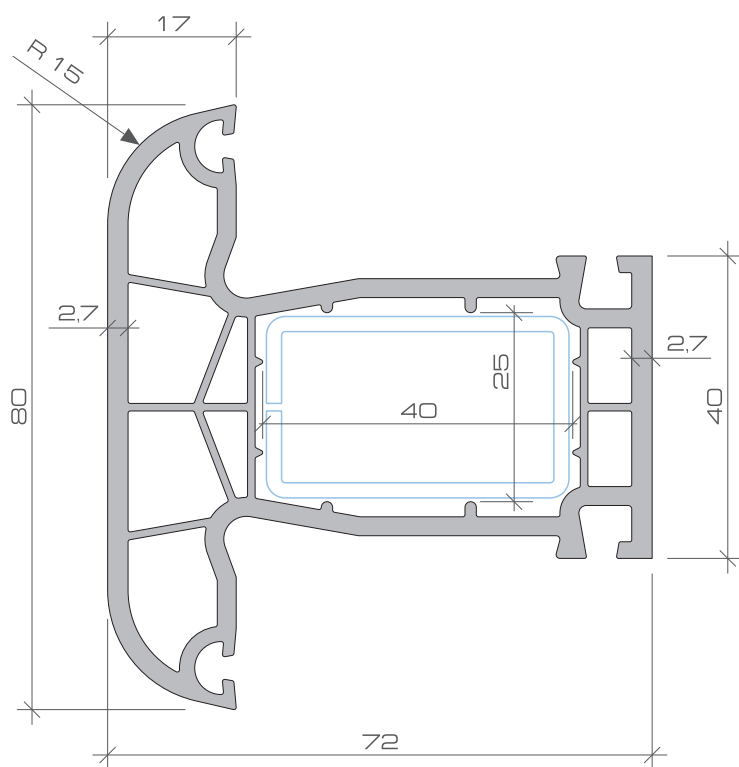

ДЕЛИТЕЛ  
 Kaempfer  
 Mullion profile  
 Profil traversa  
 WP 5003

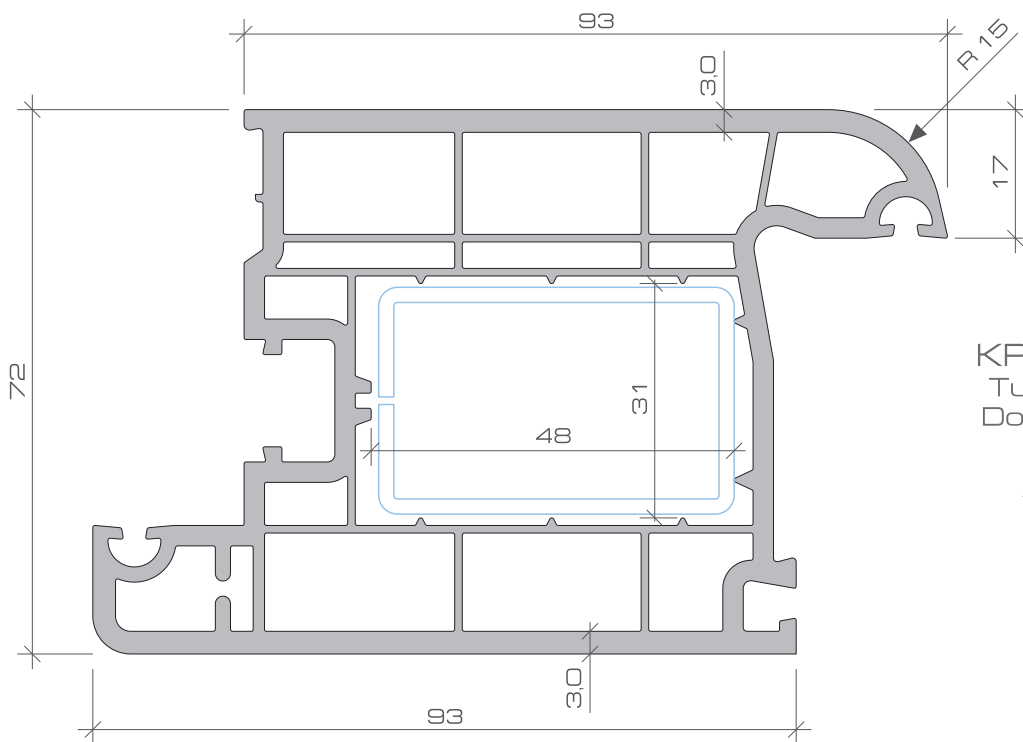

КРИЛО ВРАТА  
 Tuerfluegelprofil  
 Door sash profile  
 Profil usa

WP 5004

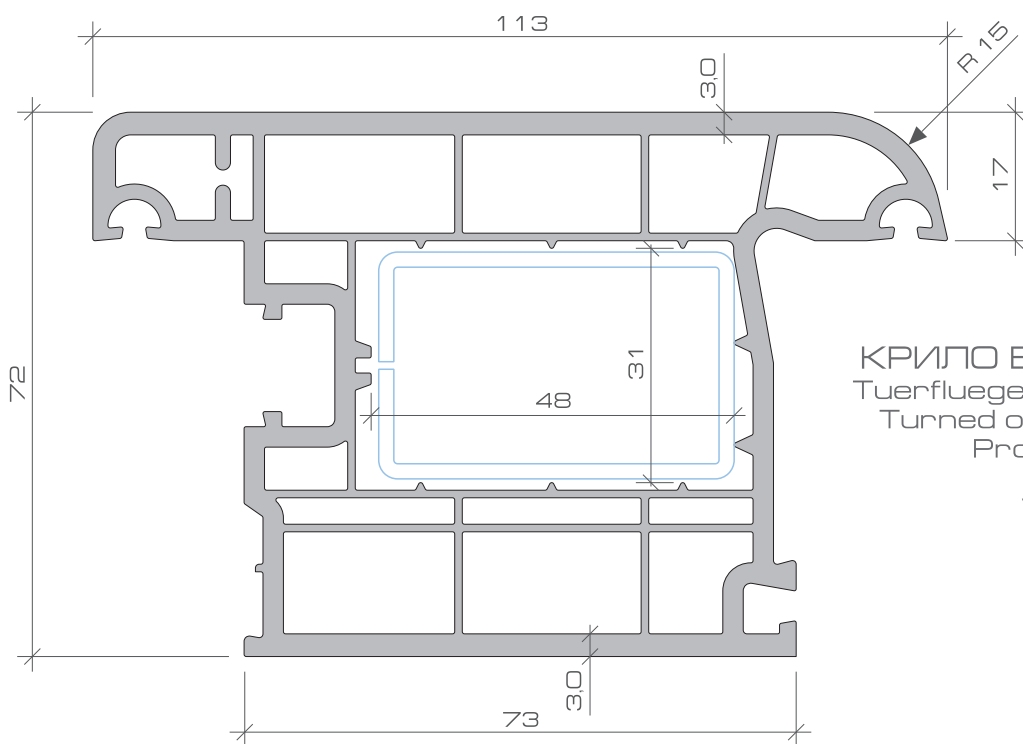

КРИЛО ВРАТА ОБЪРНАТО  
 Tuerfluegelprofil aussen oeffnend  
 Turned over door sash profile  
 Profil usa exterior

WP 5005

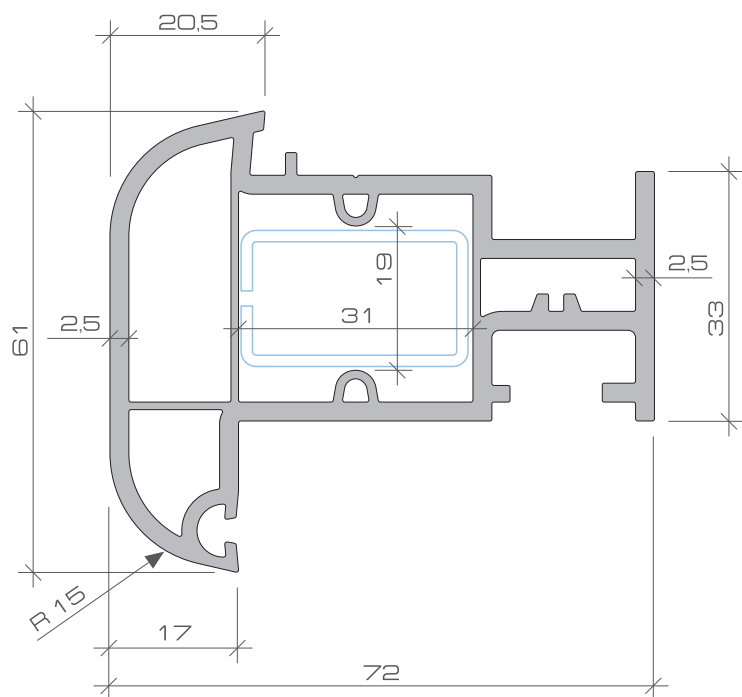

ПОДВИЖЕН ДЕЛИТЕЛ

Stulpprofil  
Lap joint profile  
Profil inversor

WP 5006

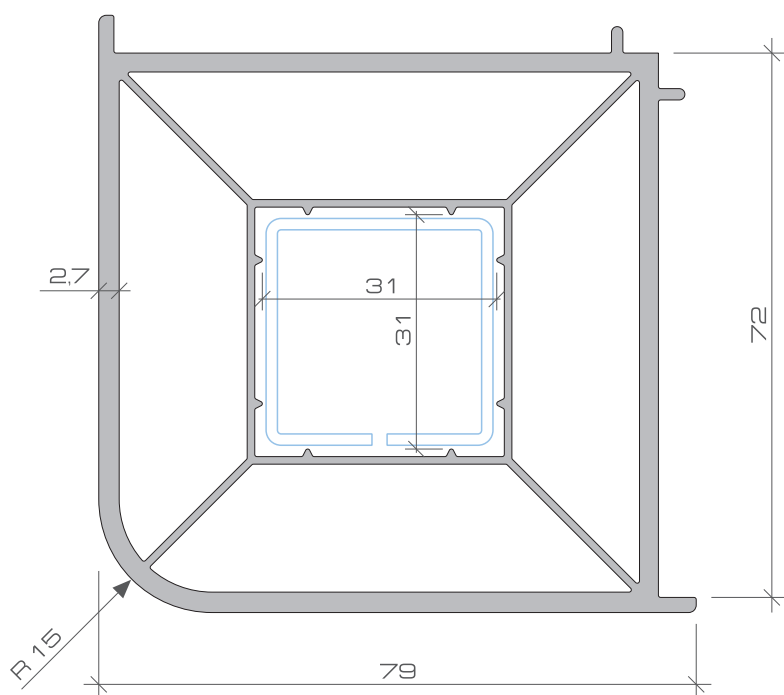

ЪГЛОВ ПРОФИЛ 90°

Eckpfosten  
Corner profil  
Profil colt 90°

WP 5007

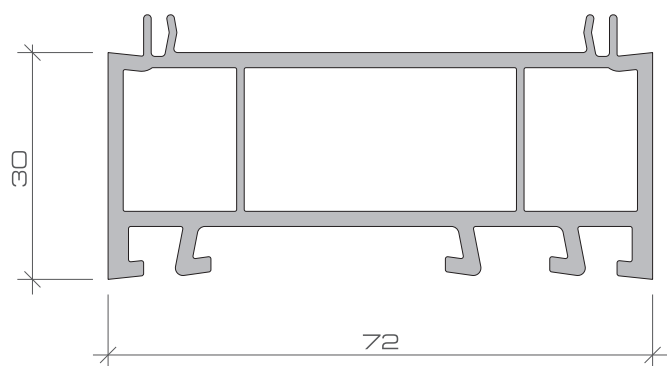

ПРОФИЛ УДЪЛЖИТЕЛ  
Verlaengerung  
Frame extension  
Inversor

WP 5008

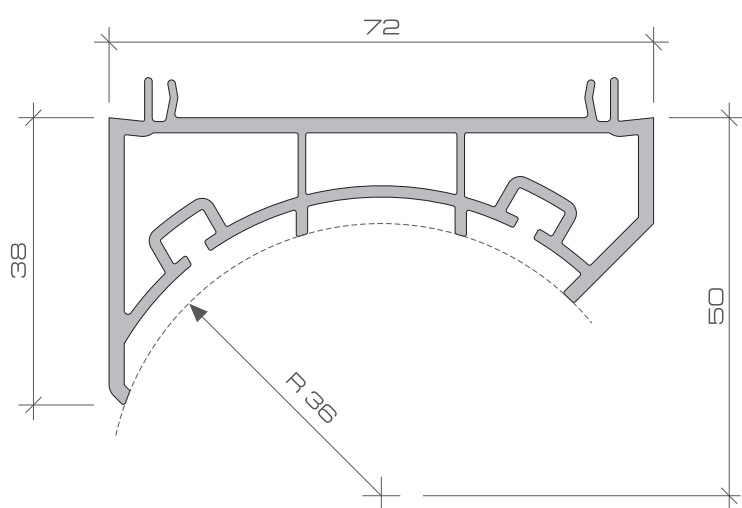

АДАПТОР  
Eckprofil variabler winkel  
Corner lag profile  
Profil adaptor

WP 5009

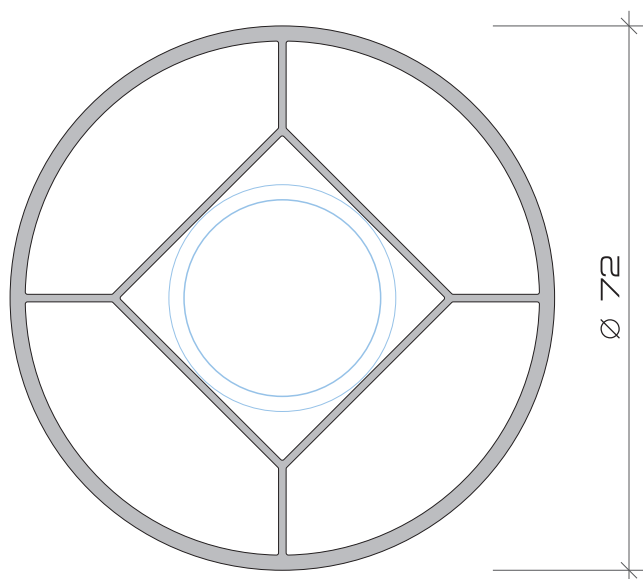

ТРЪБА  
Rohr variabler winkel  
Pipe profile  
Profil teava

WP 5011

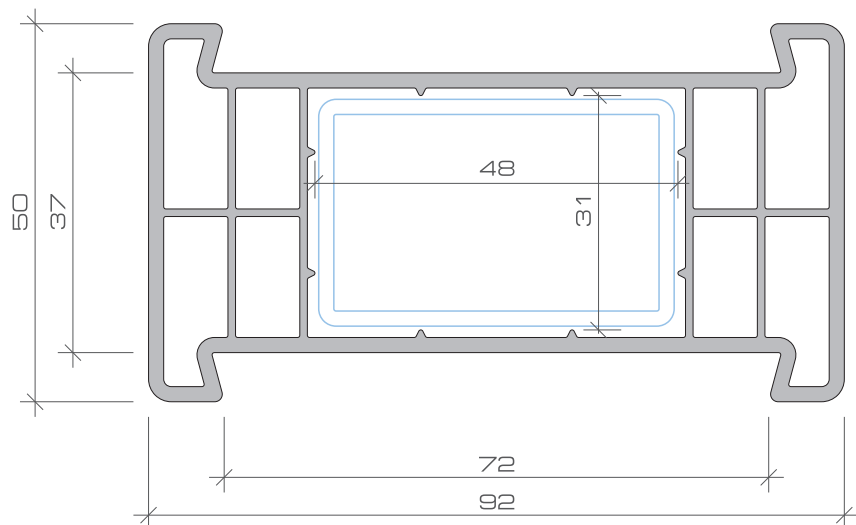

ПРИСЪЕДИНИТЕЛ  
ГОЛЯМ

Verbindungsprofil  
Coupling profile  
Profil conector mare

WP 5013

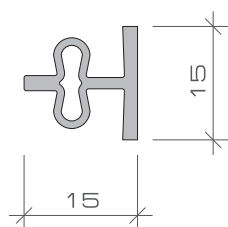

ПРИСЪЕДИНИТЕЛ

Verbindungsprofil  
Coupling profile  
Profil conector

WP 5012

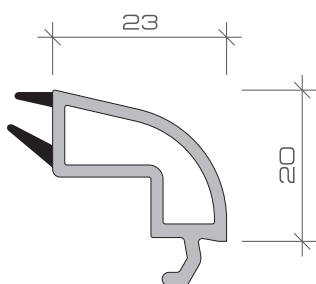

СТЪКЛОДЪРЖАТЕЛ 24 mm

Glasleiste 24  
Glass bead 24  
Bagheta 24 mm

WP 5020

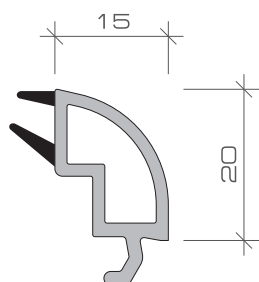

СТЪКЛОДЪРЖАТЕЛ 32 mm

Glasleiste 32  
Glass bead 32  
Bagheta 32 mm

WP 5030



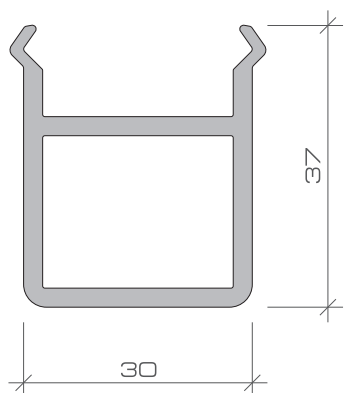

ПОВДИГАЩ ПРОФИЛ  
Lifting profile  
Hebeprofil  
WP 4123

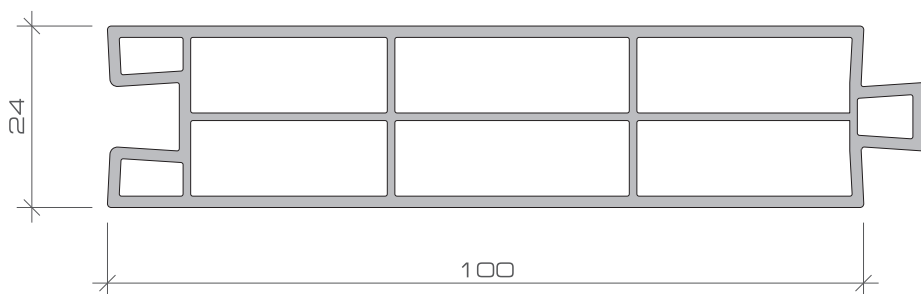

ПАНЕЛ 24 mm  
PVC Bindeplatte 24 mm  
PVC panel 24 mm  
Lambriu 24 mm  
WP 4119

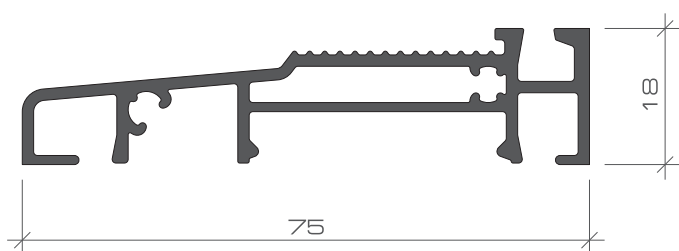

АЛУМИНИЕВ ПРАГ  
Aluminium Tuerschwelle  
Aluminium door - sill  
Prag din aluminiu  
WP 5065

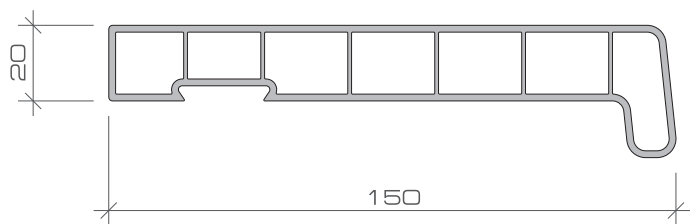

WP 4114

ПОДПРОЗОРЕЧЕН ПРОФИЛ  
Fensterbank  
Under window profile  
Profil glaf

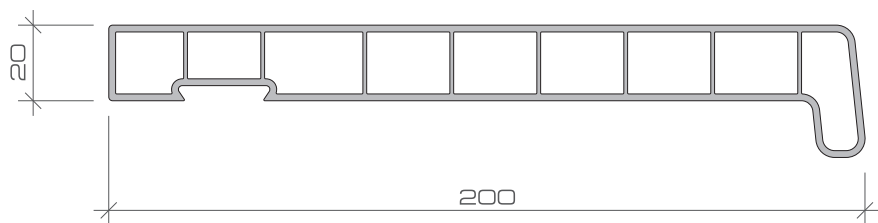

WP 4115

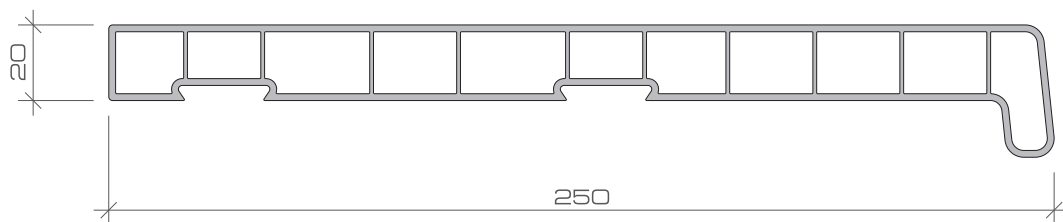

WP 4116

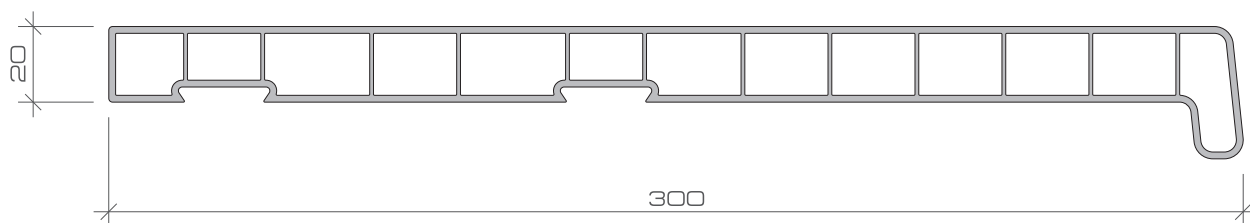

WP 4117

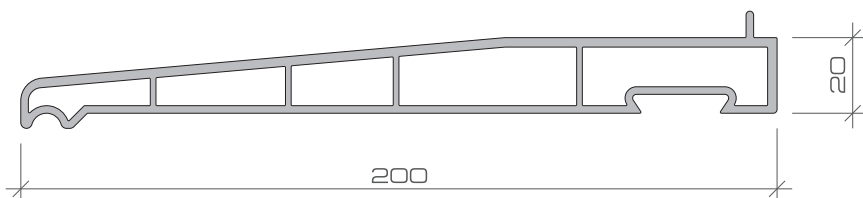

WP 4125

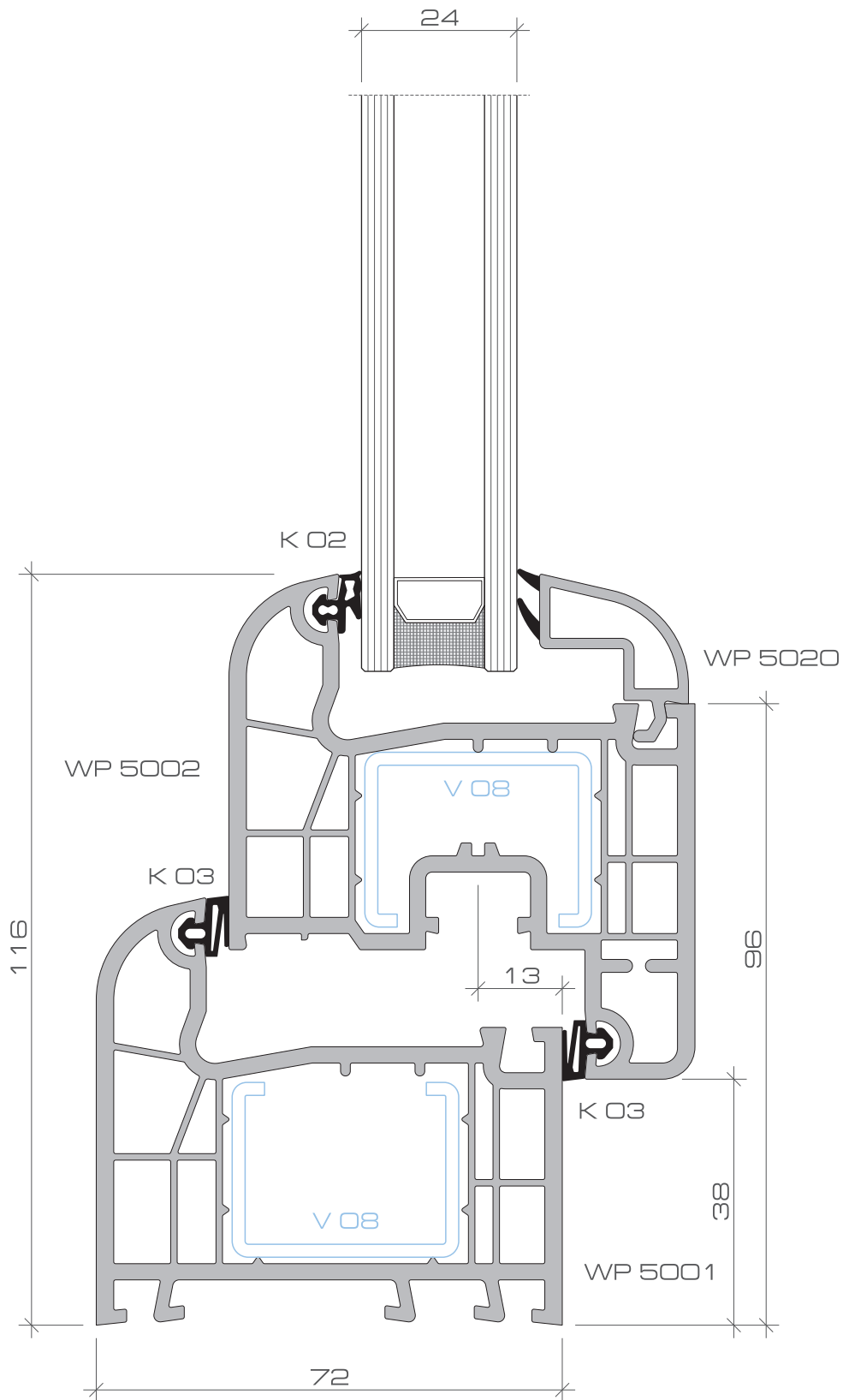

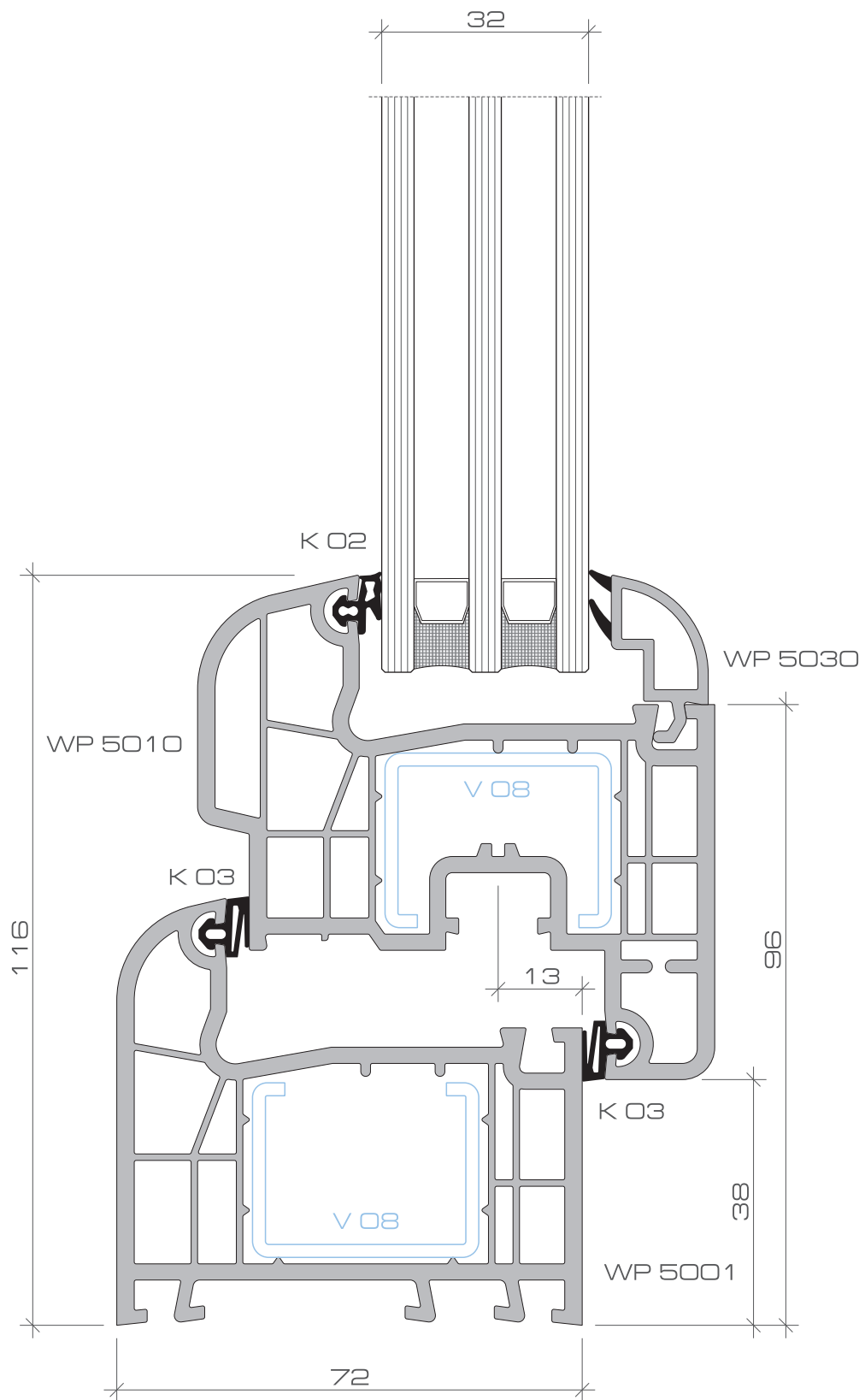

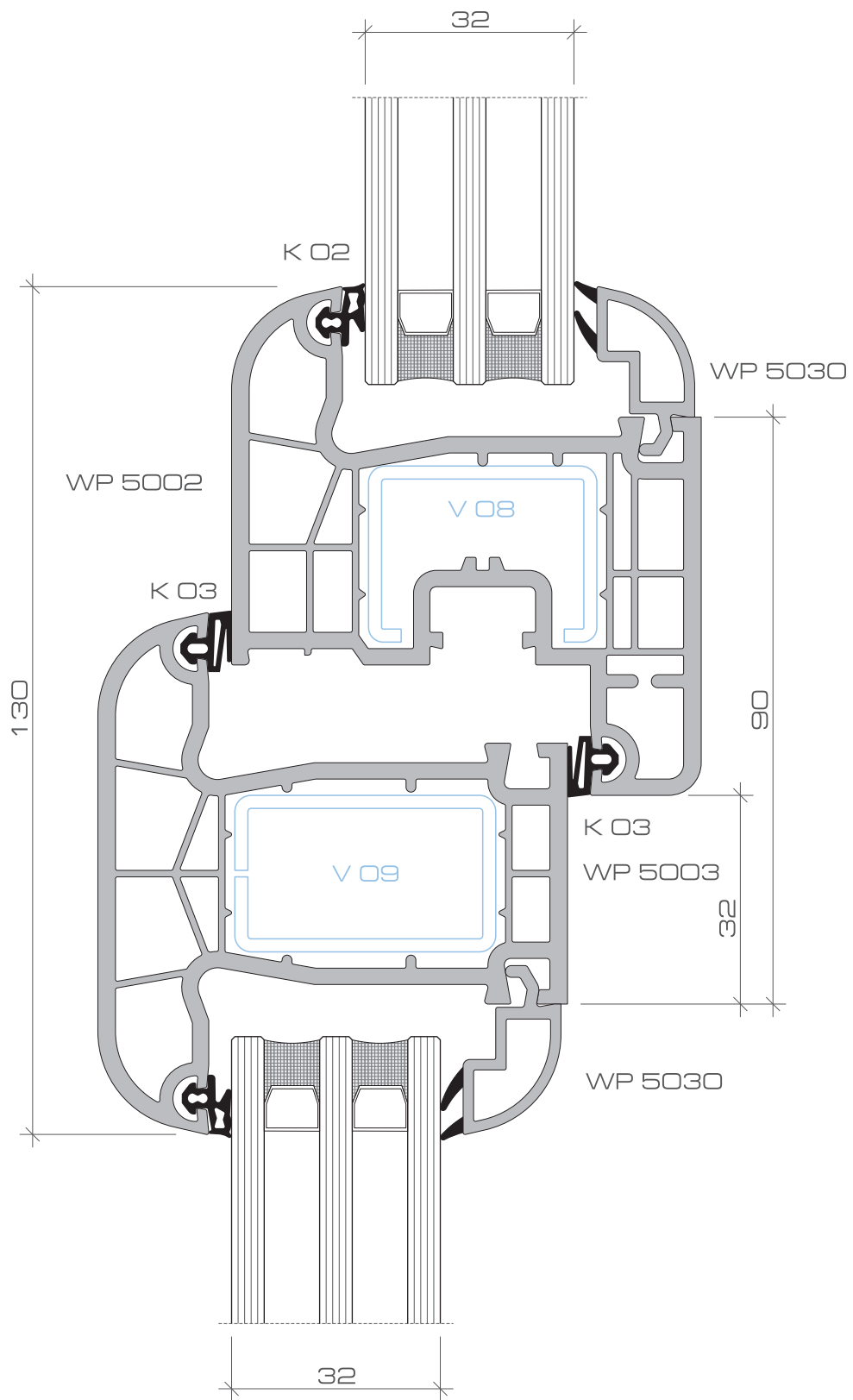

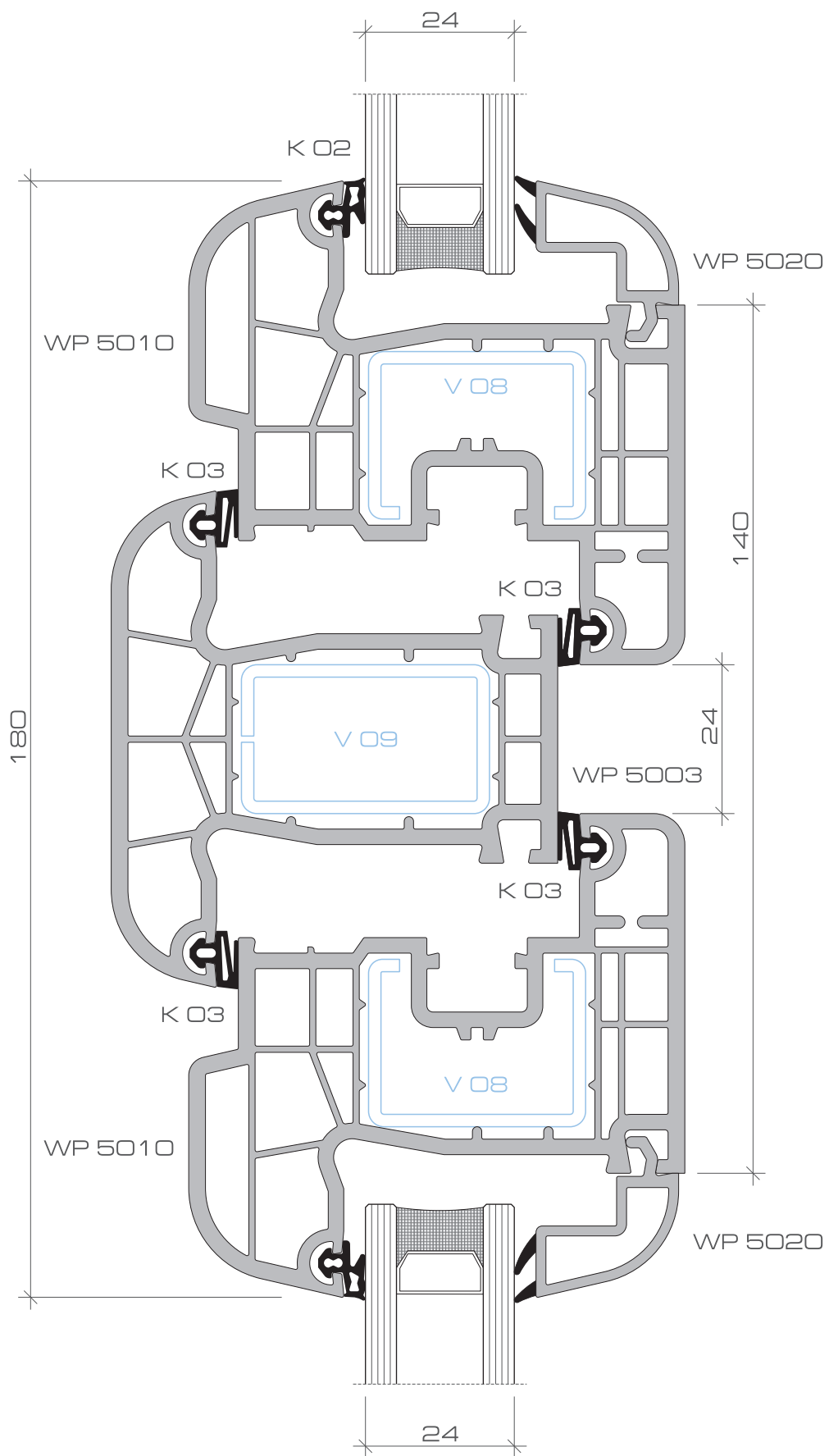

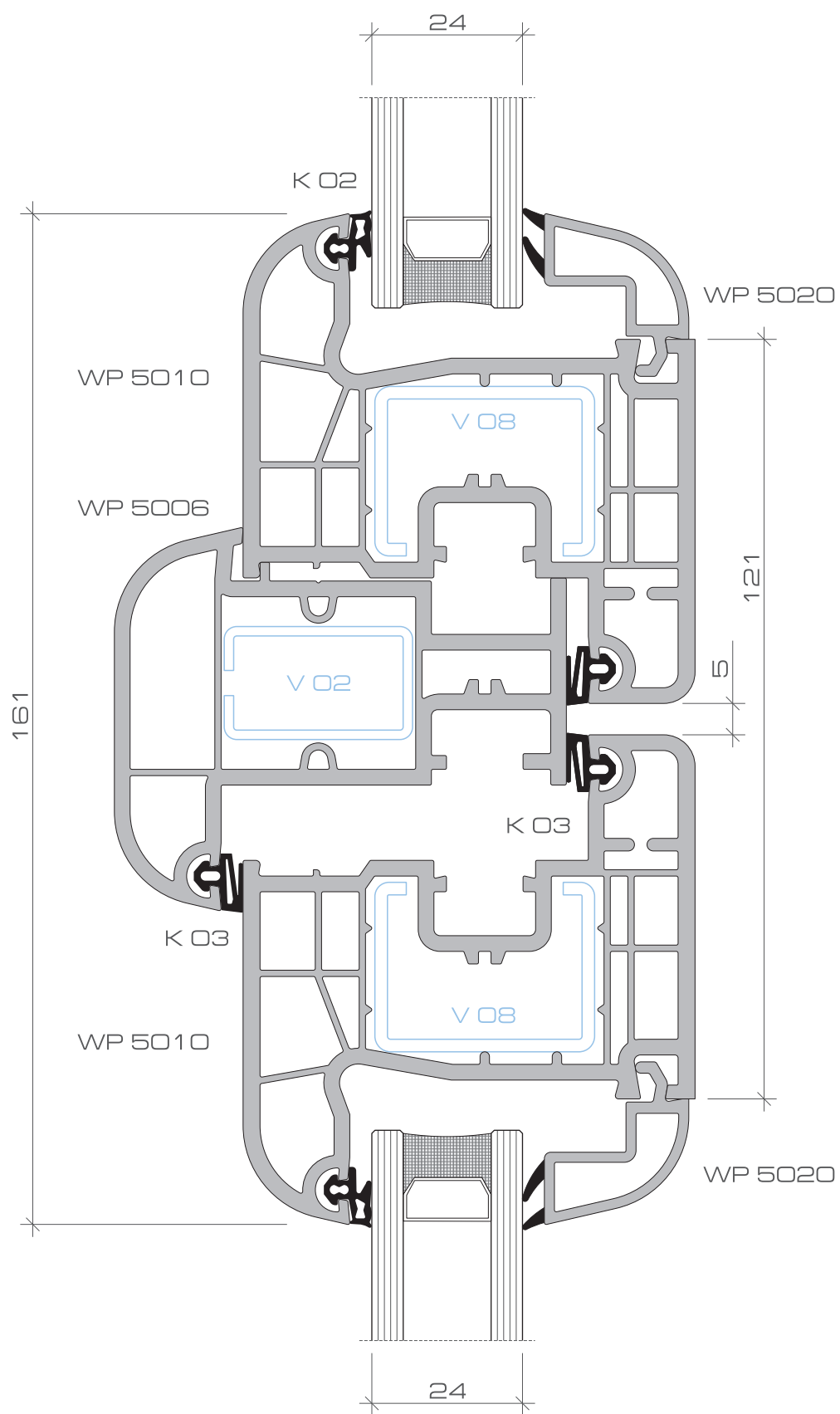

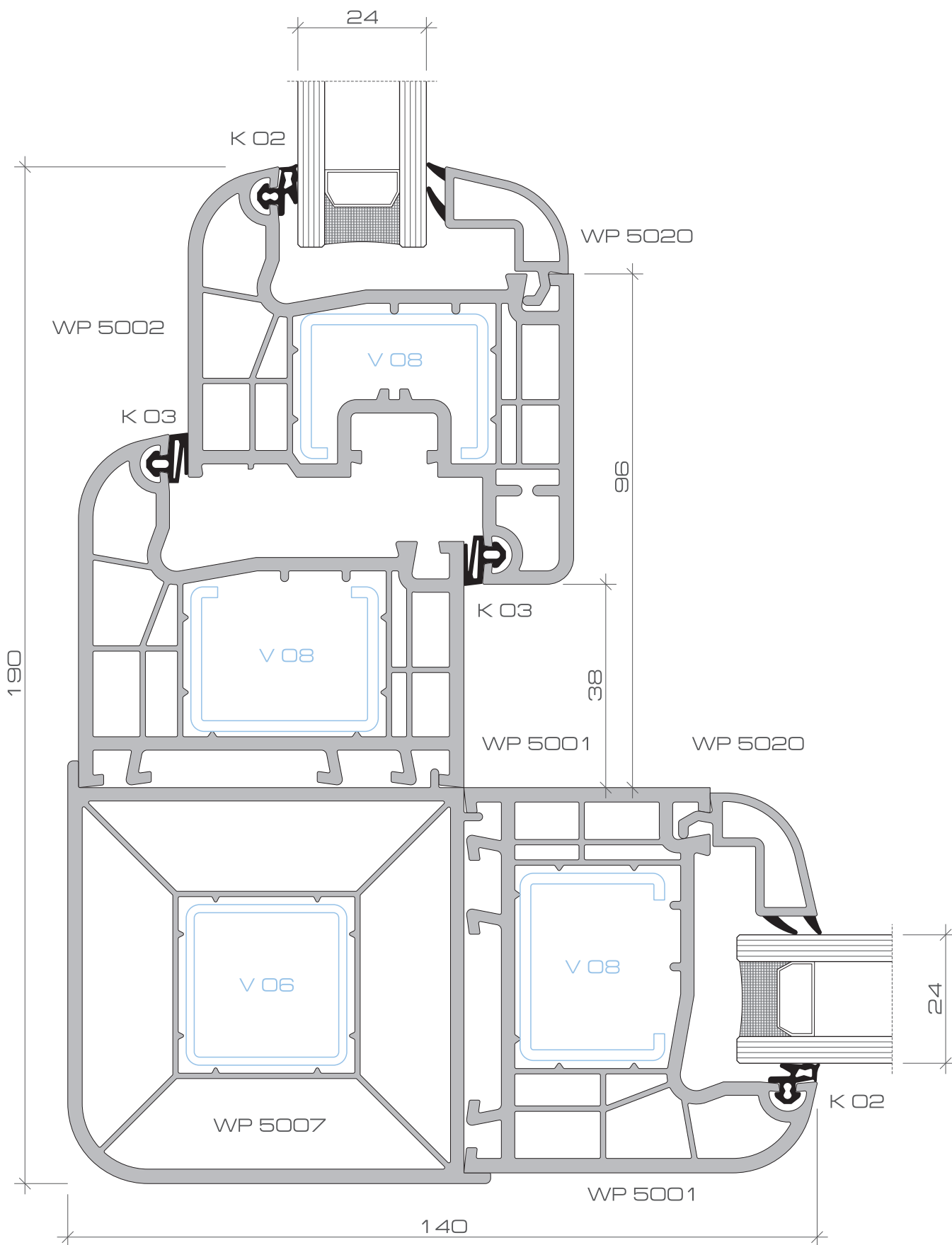



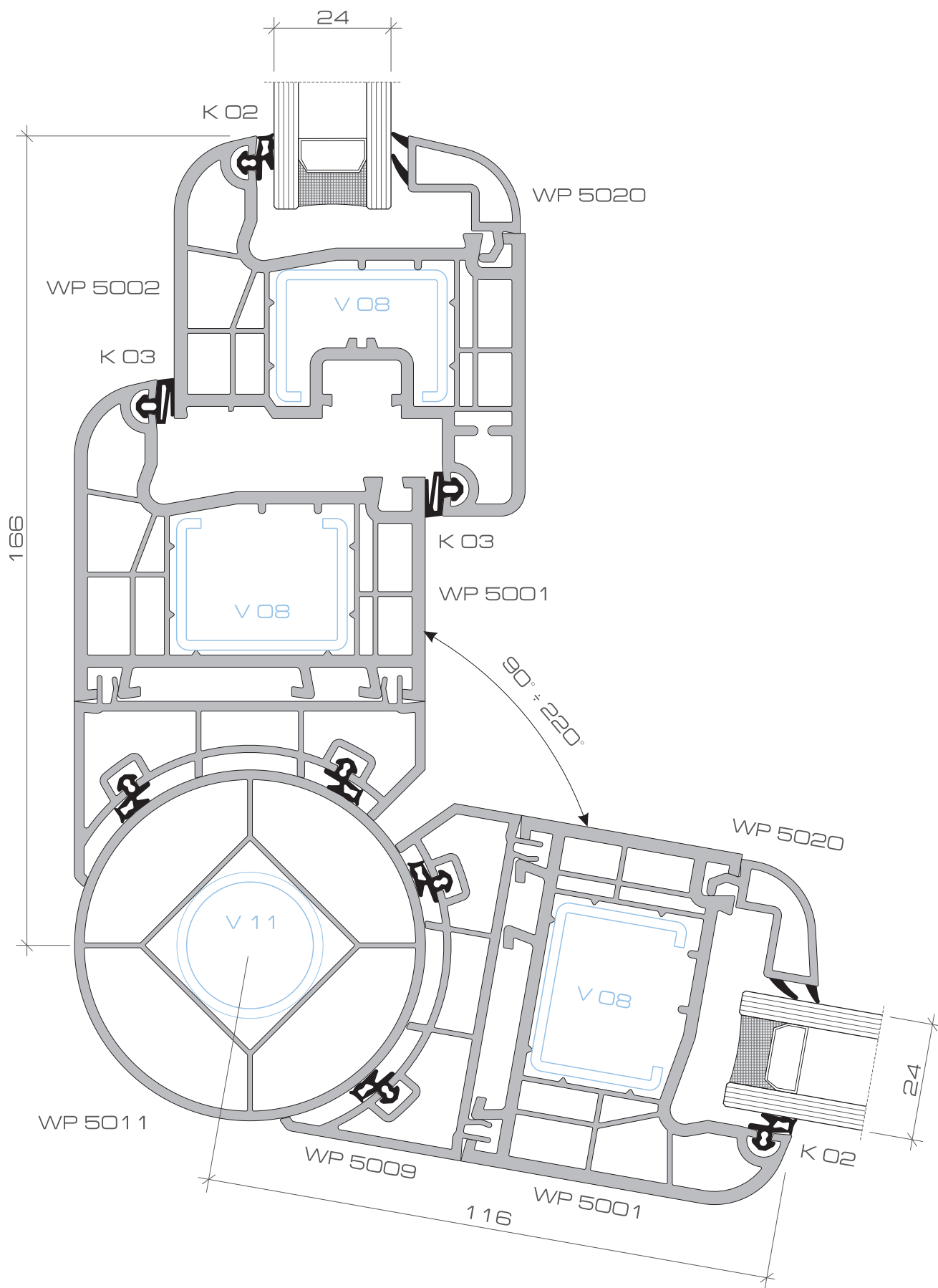

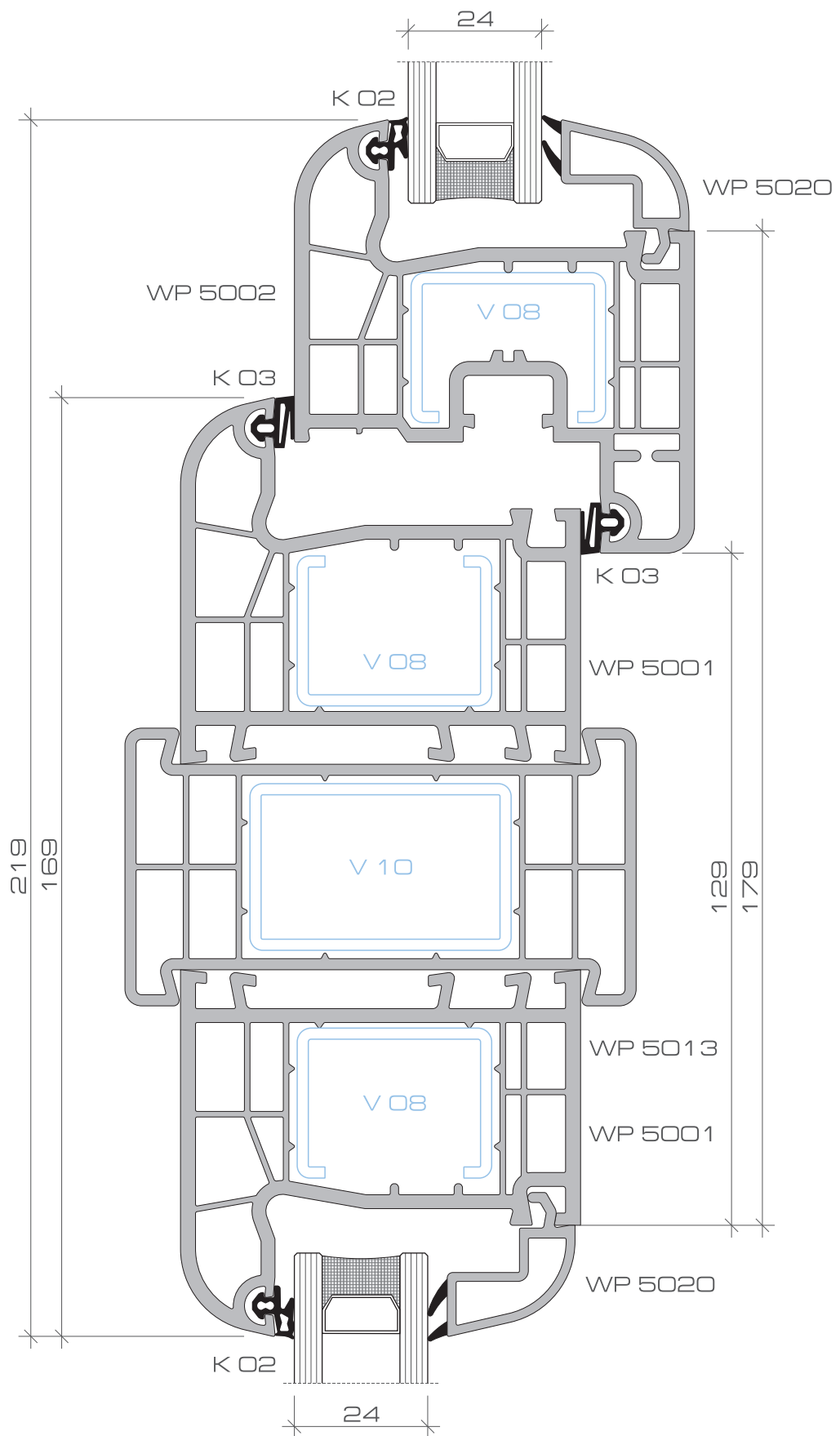

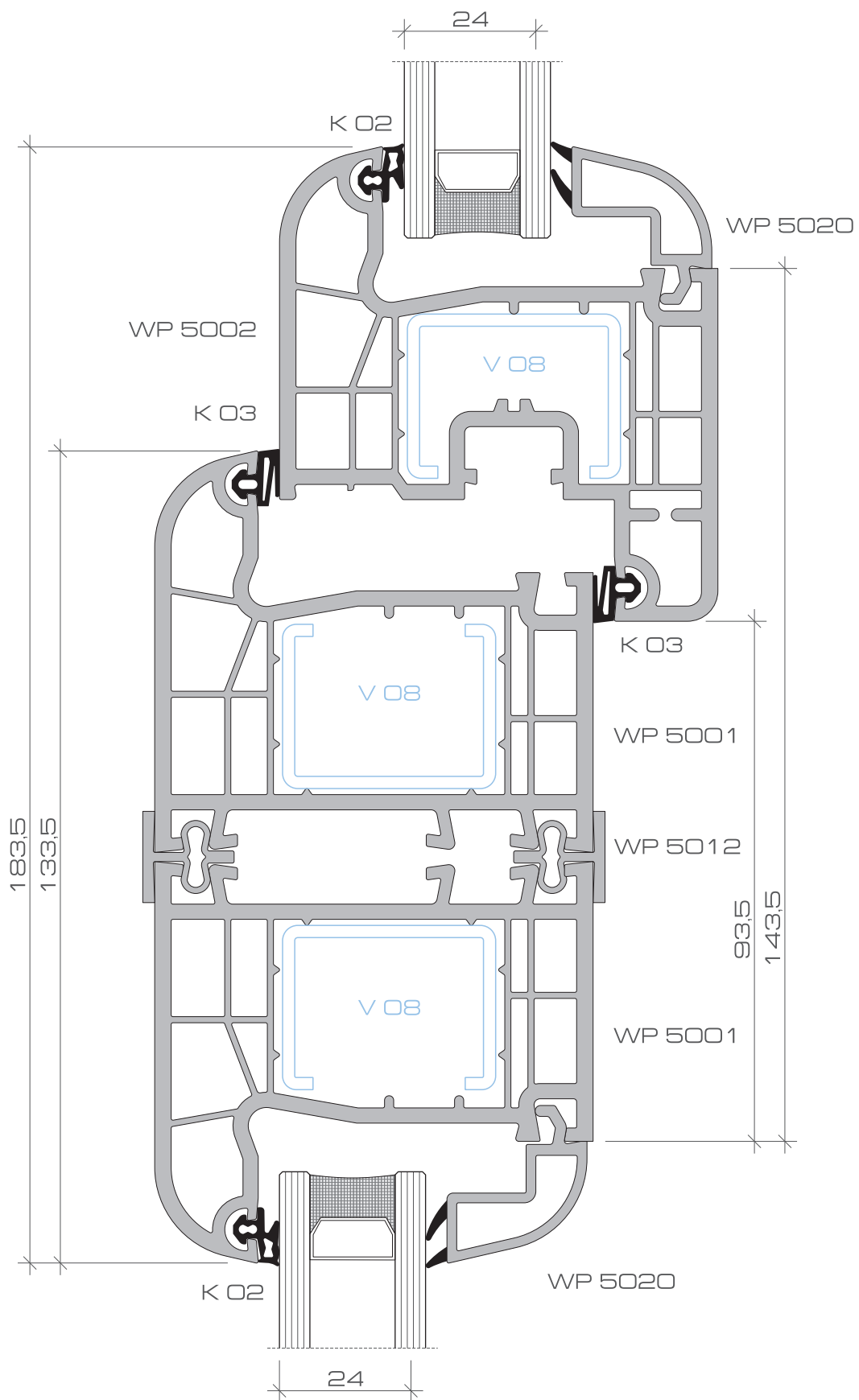

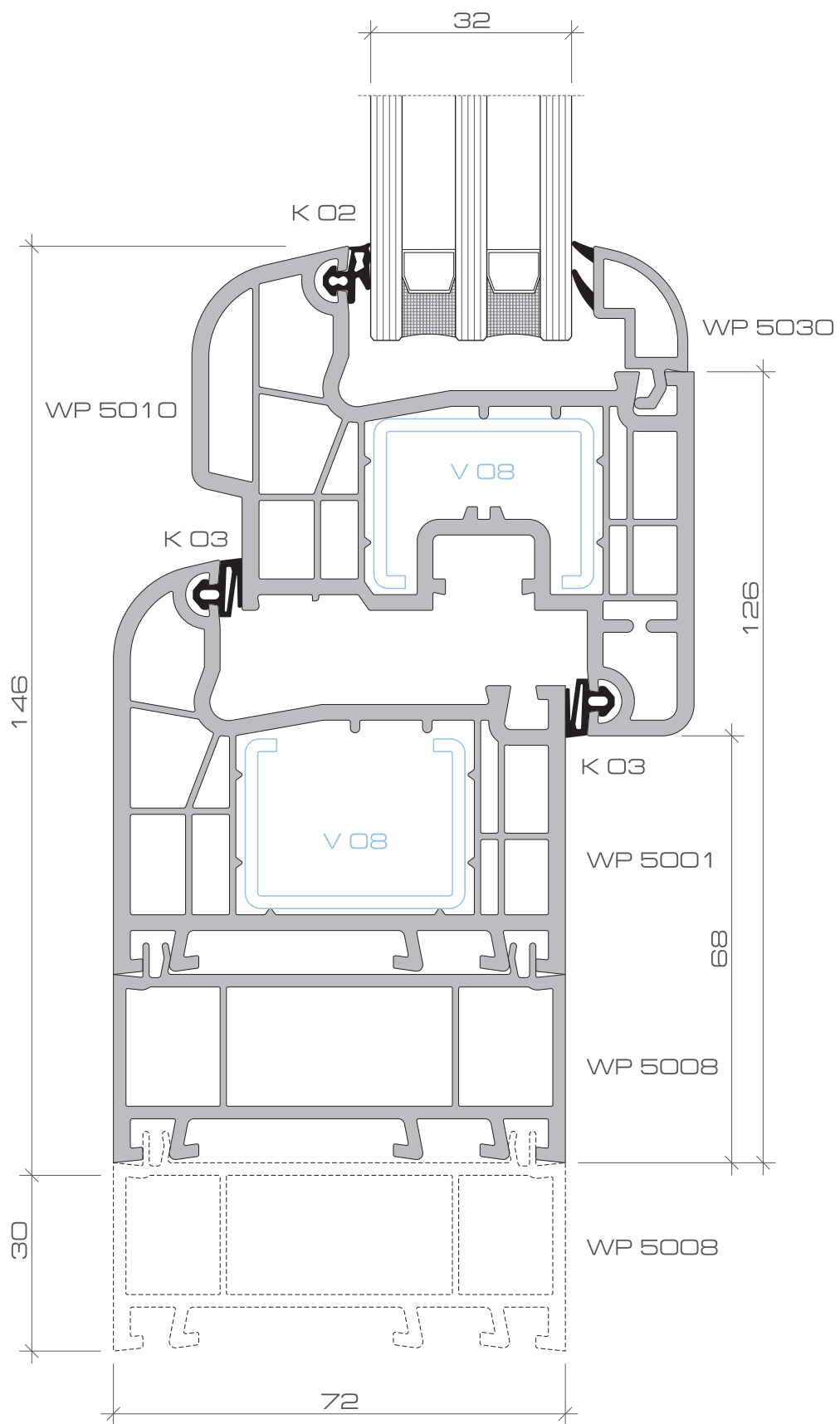

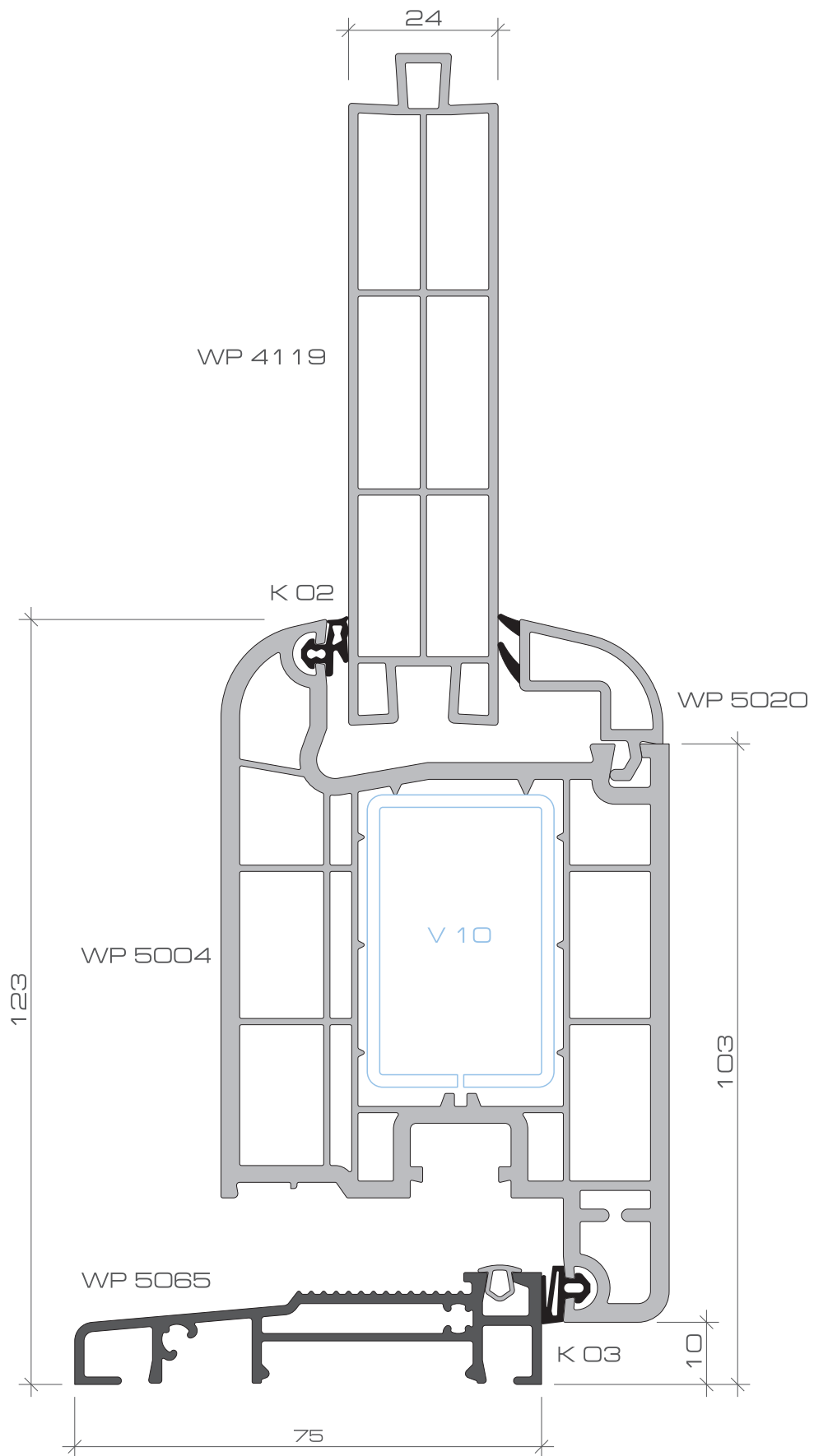

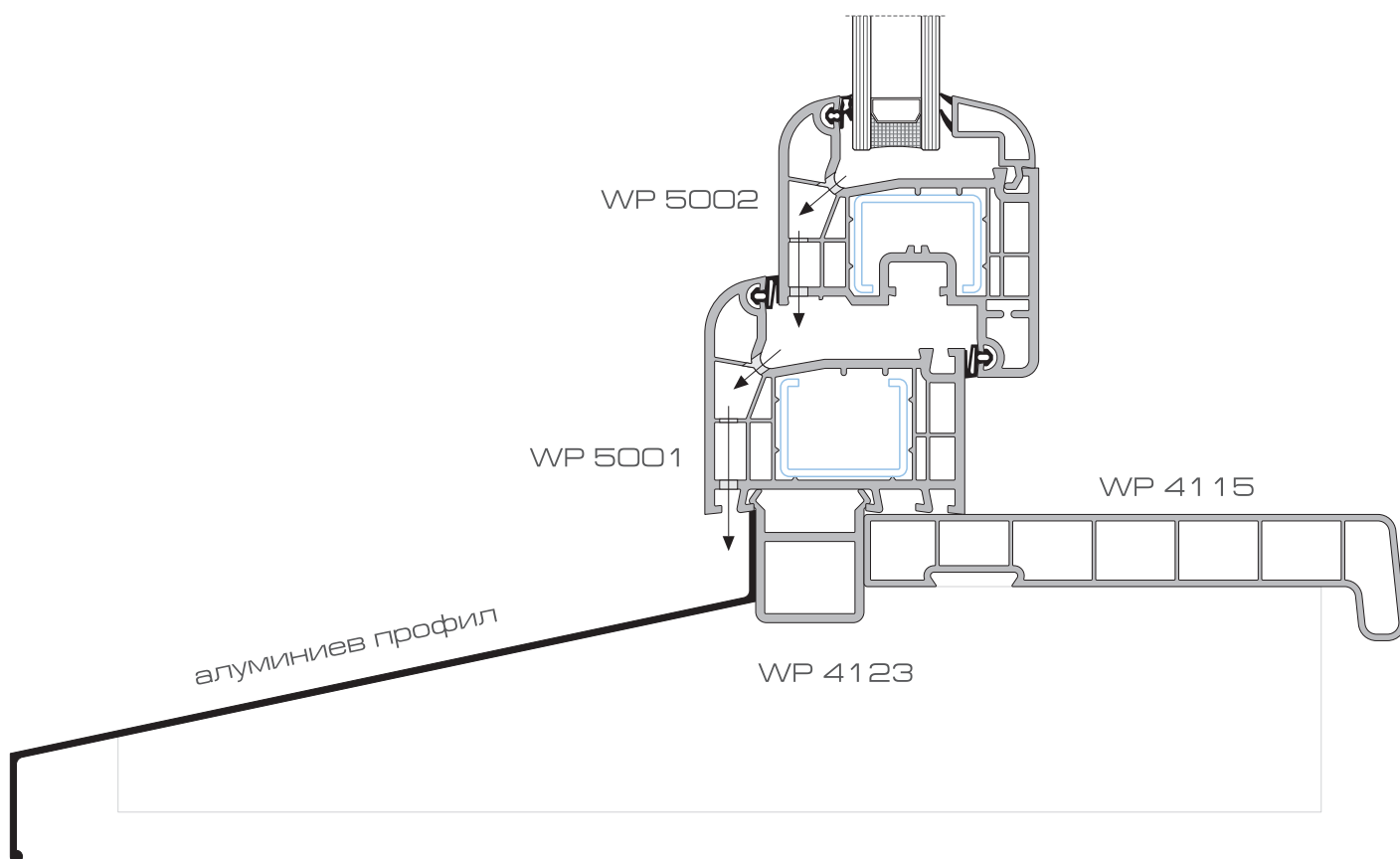
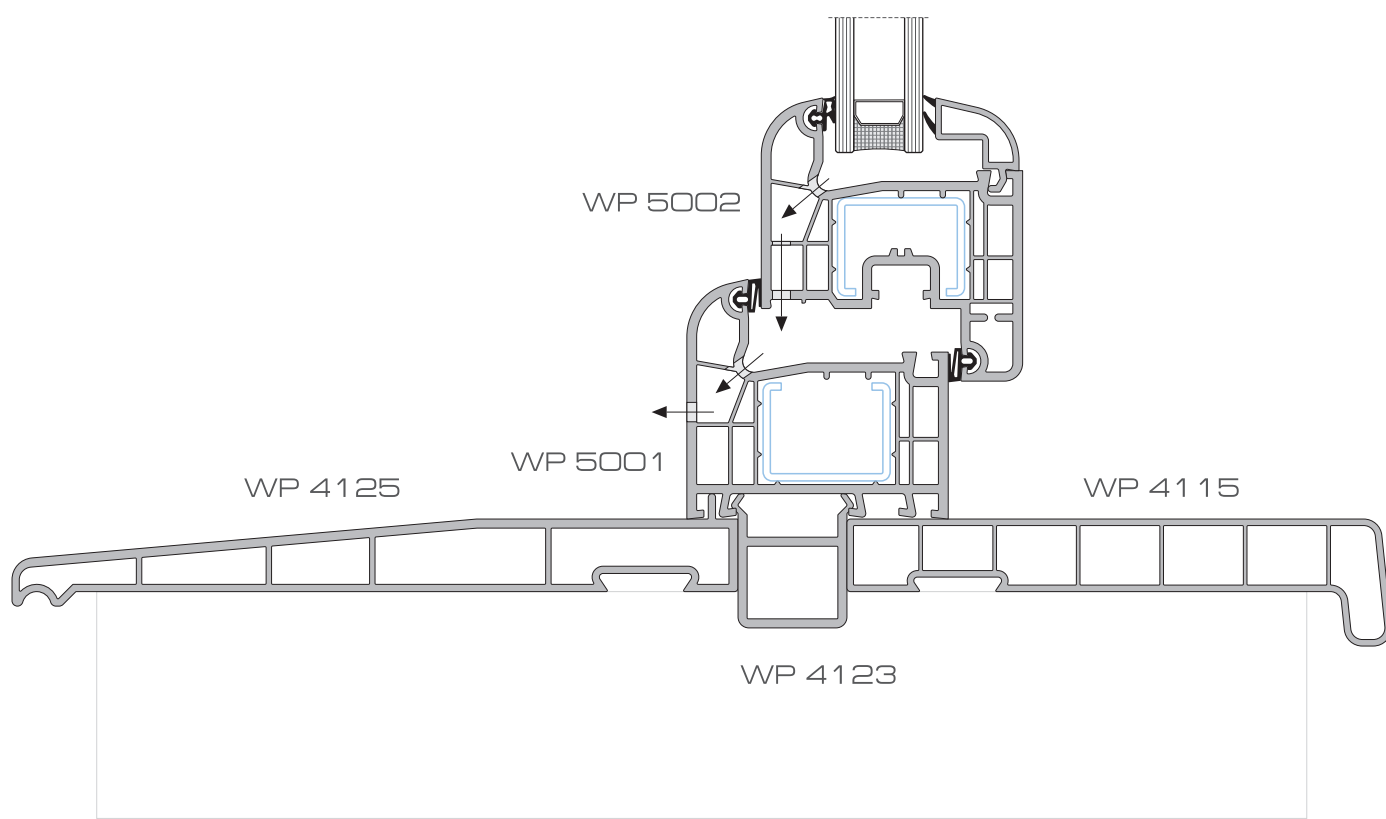

# СХЕМА ЗА ВОДООТЛИВАНЕ

Drainage diagram/ Abwasserungsschema / Schema pentru scurgere apa

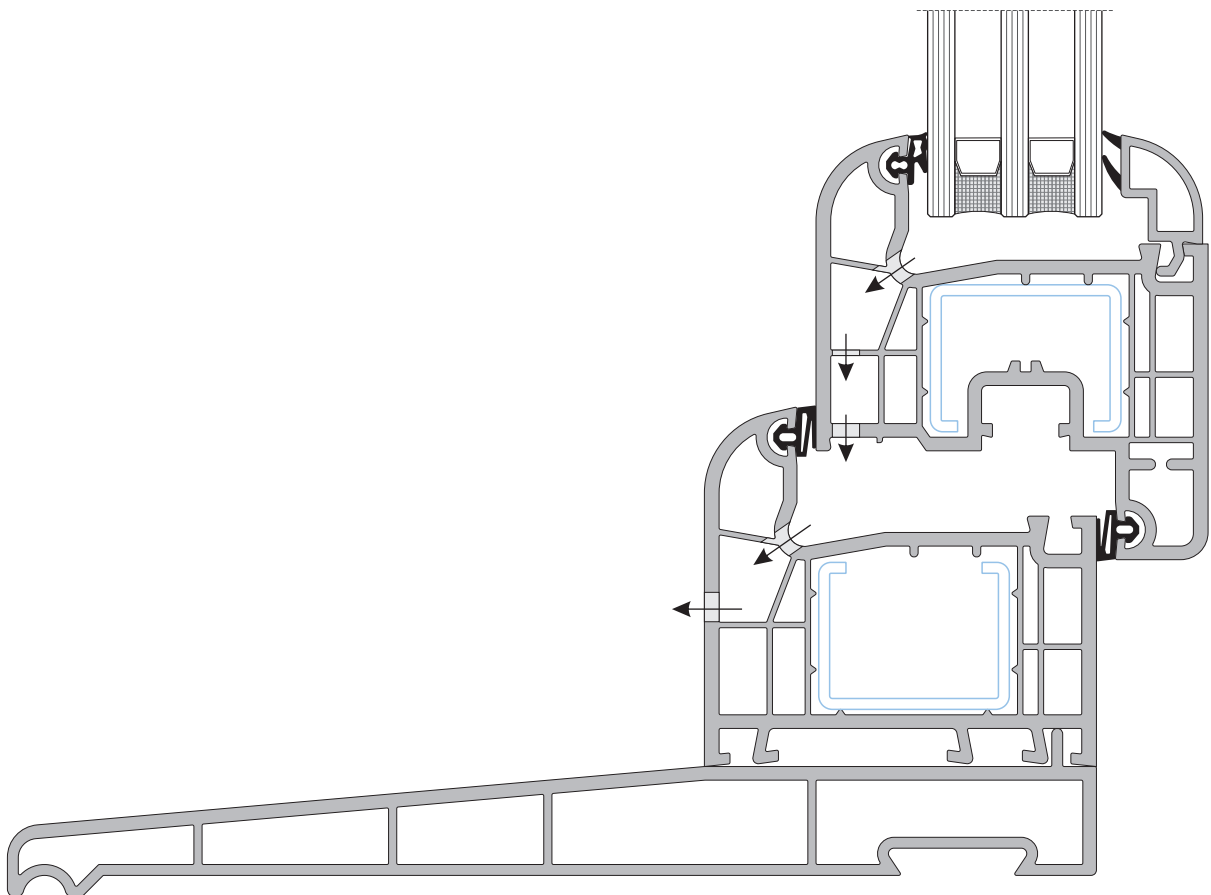
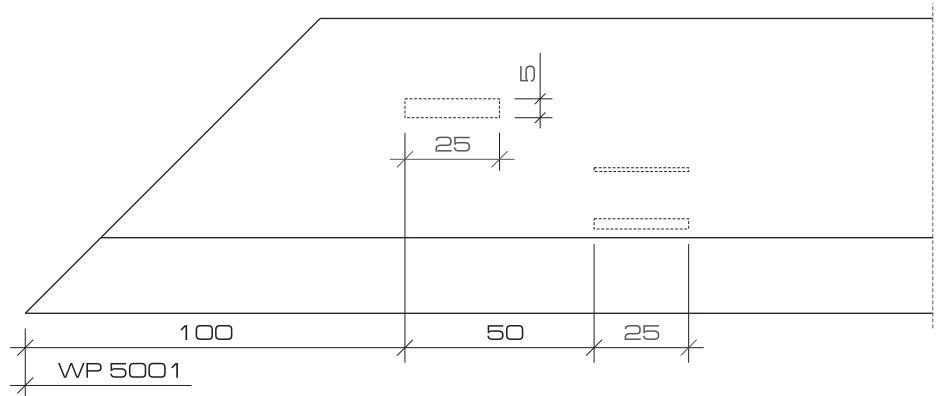
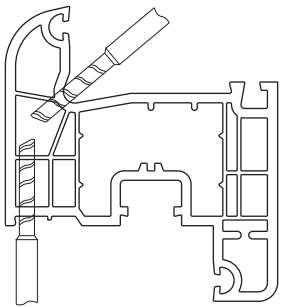
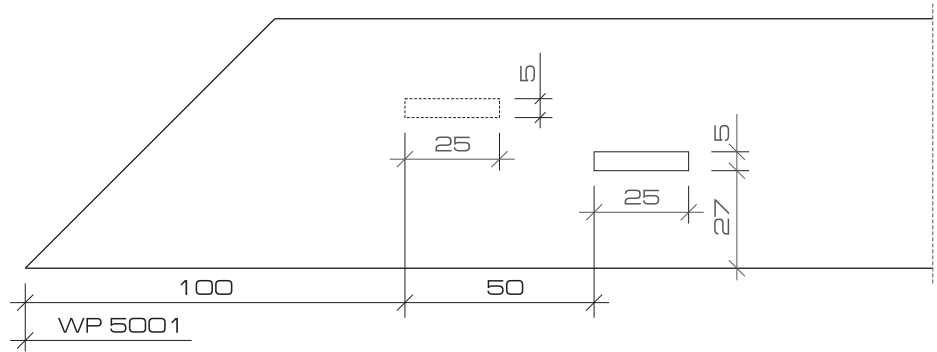
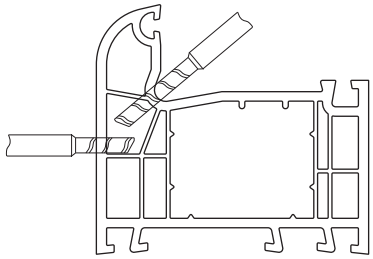

# СХЕМА ЗА ФРЕЗОВАНЕ НА ДЕЛИТЕЛ

Mullion milling / Kaempferfrasenschema / Schema pentru frezarea traversei

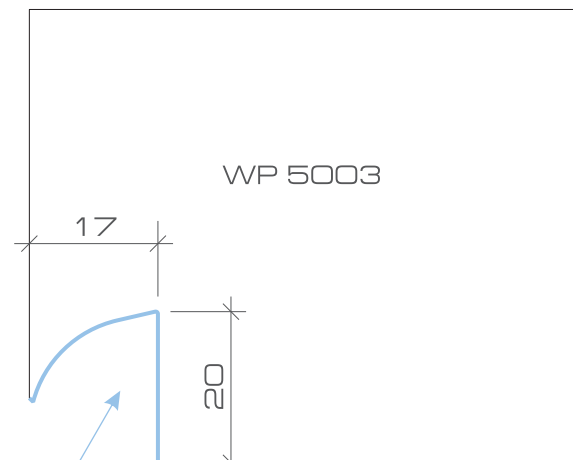

WP 5003  
17  
20  
КОНТУР НА ФРЕЗОВАНЕ  
line of milling  
Fräsekontur  
contur pentru frezare

ПЛАСТМАСОВА СГЛОБКА  
plastic joint  
Plastikzusammensetzung  
conector din plastic

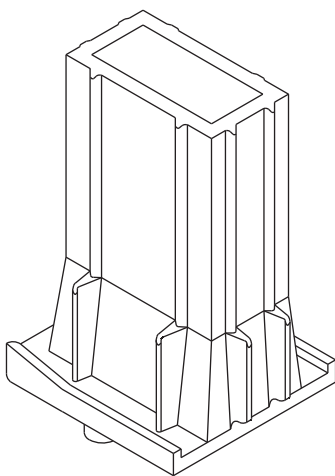

МЕТАЛНА СГЛОБКА  
metal joint  
Metallzusammensetzung  
conector metalic

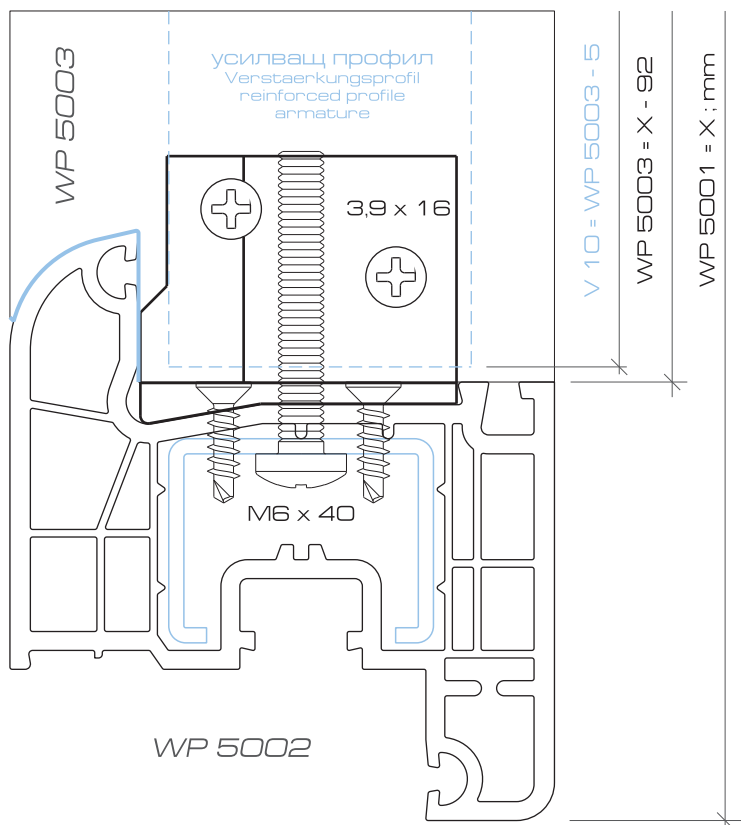
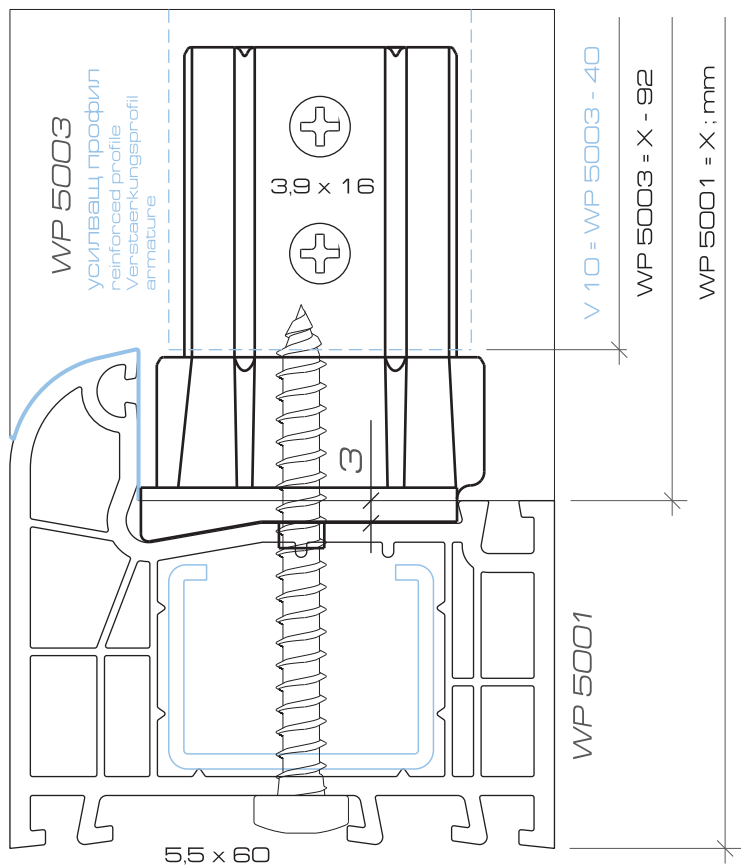
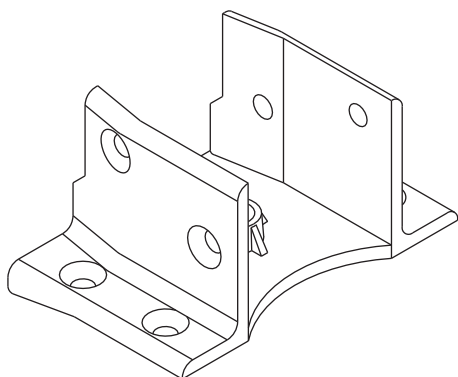



# СХЕМА ДЕЛИТЕЛ - КАСА

Schema Kaempfer - Rahmen/ Scheme mullion - frame/  
Schema de montaj traversa - toc

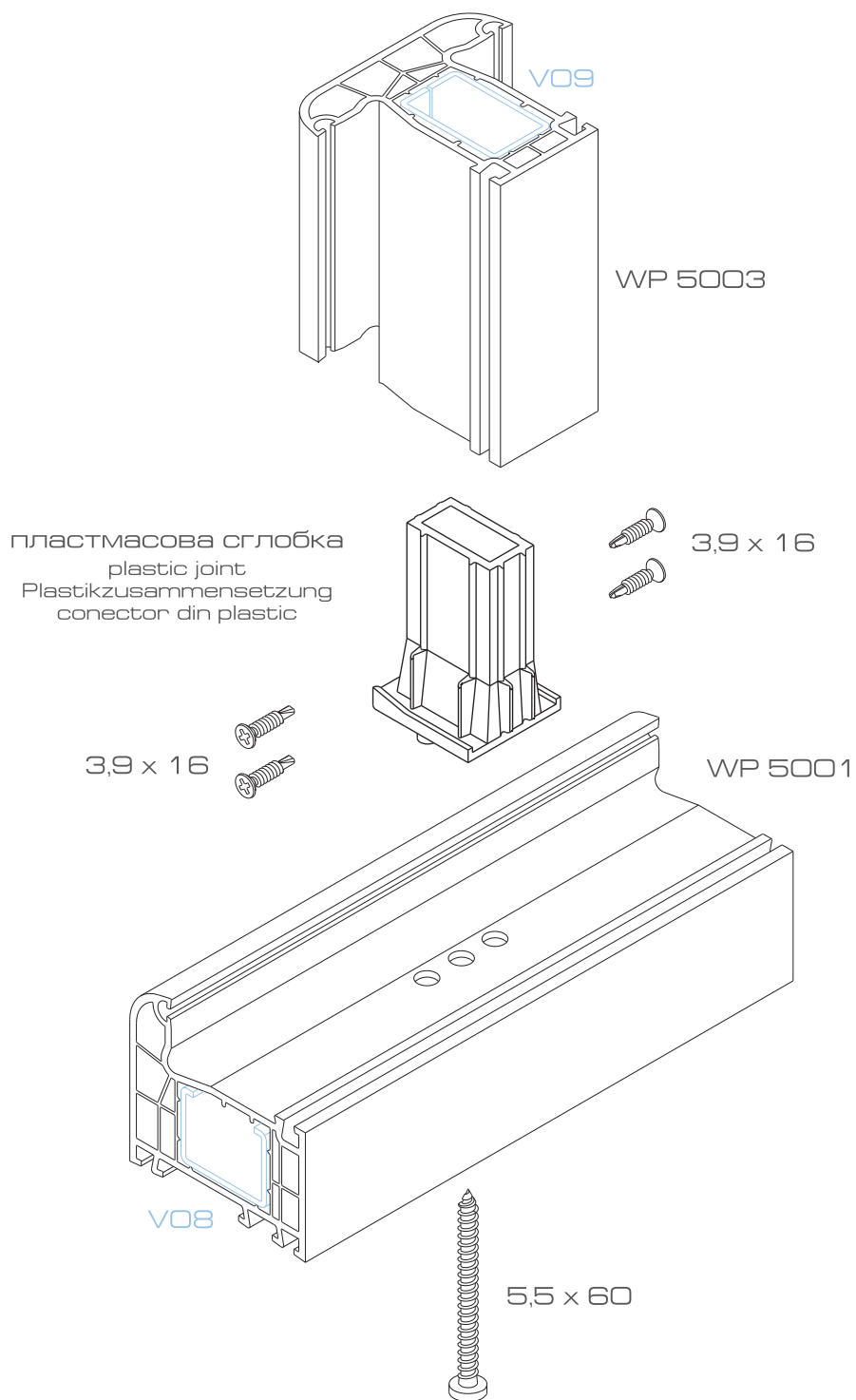

# СХЕМА ДЕЛИТЕЛ - ДЕЛИТЕЛ

Schema Kaempfer - Kaempfer / Scheme mullion - mullion  
Schema de montaj traversa - traversa

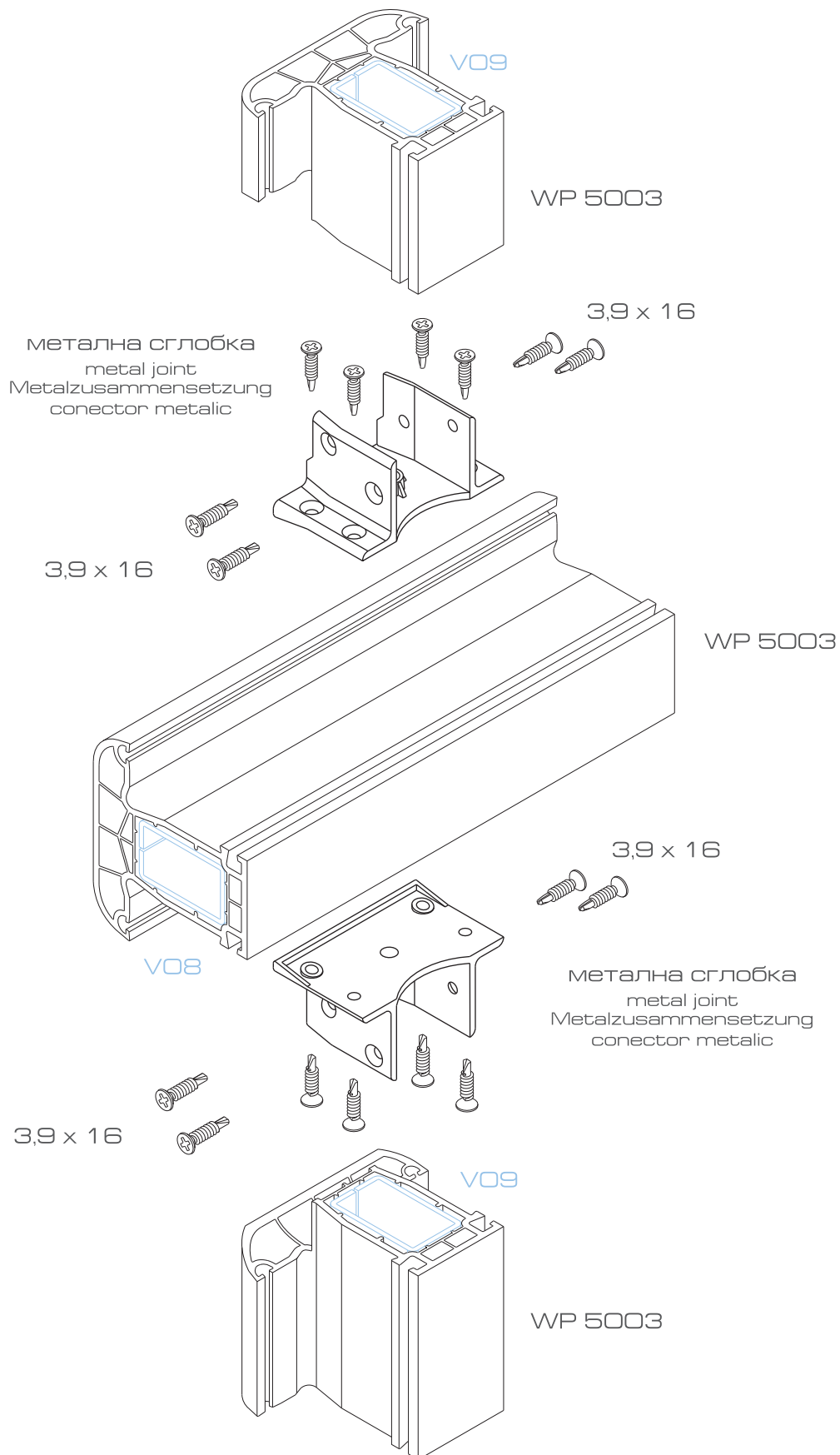

# СХЕМА ПОДВИЖЕН ДЕЛИТЕЛ

Schema Stulpkaempfer/ Scheme lap joint profile/ Schema de montaj inversor

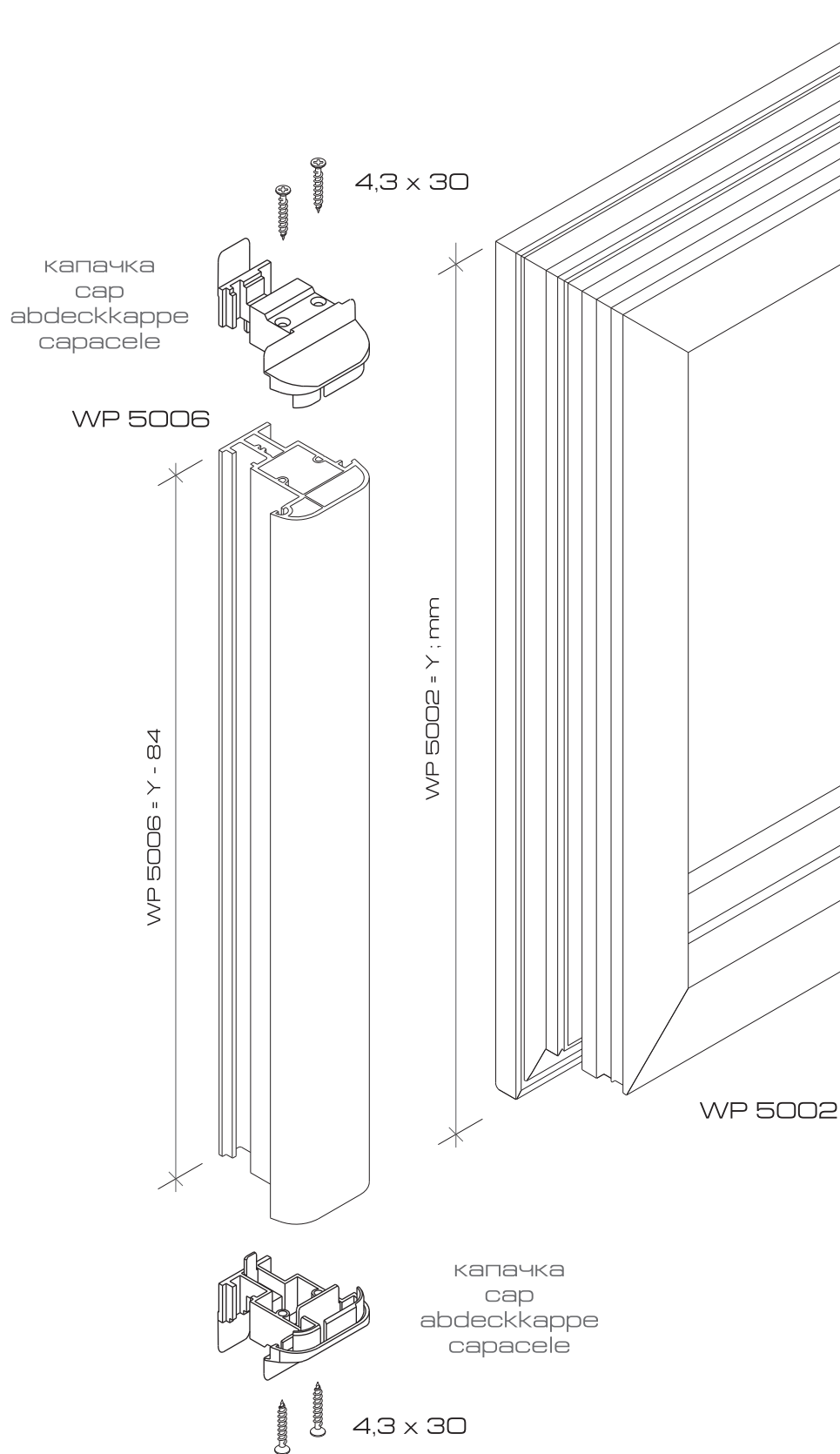

# УСИЛВАЩИ ПРОФИЛИ

Verstaerkungsprofile/ Reinforced profiles/ Armature

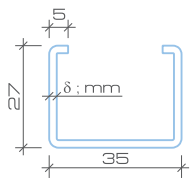
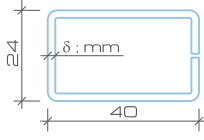
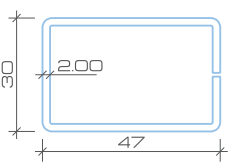
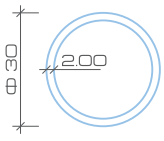
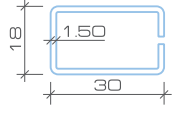
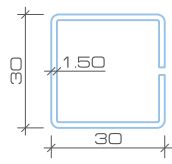
Код	PVC Профил PVC Profile PVC profil PVC profil	Усилващ профил Verstaerkungsprofile Reinforced profiles Armature	 Инерционен МОМЕНТ Inertia moment Trägheitsmoment momentului inert
V08	WP 5001 WP 5002 WP 5010		$\delta = 1,5$ $I_x = 1,22 \text{ cm}^4$ $I_y = 2,80 \text{ cm}^4$
			$\delta = 2$ $I_x = 1,51 \text{ cm}^4$ $I_y = 3,53 \text{ cm}^4$
V09	WP 5003		$\delta = 1,5$ $I_x = 1,71 \text{ cm}^4$ $I_y = 3,76 \text{ cm}^4$
			$\delta = 2$ $I_x = 2,14 \text{ cm}^4$ $I_y = 4,76 \text{ cm}^4$
V10	WP 5004 WP 5005 WP 5013		$I_x = 4,17 \text{ cm}^4$ $I_y = 8,35 \text{ cm}^4$
V11	WP 5011		$I_x = 1,73 \text{ cm}^4$ $I_y = 1,73 \text{ cm}^4$
V02	WP 5006		$I_x = 0,67 \text{ cm}^4$ $I_y = 1,46 \text{ cm}^4$
V06	WP 5007		$I_x = 2,19 \text{ cm}^4$ $I_y = 2,25 \text{ cm}^4$

# УСИЛВАЦИ ПРОФИЛИ

Графики за определяне максималните размери на крилата  
 Graphiken zur Bestimmung der maximalen Flügelgrösse  
 Grafice pentru definirea marimii maxime ale aripilor

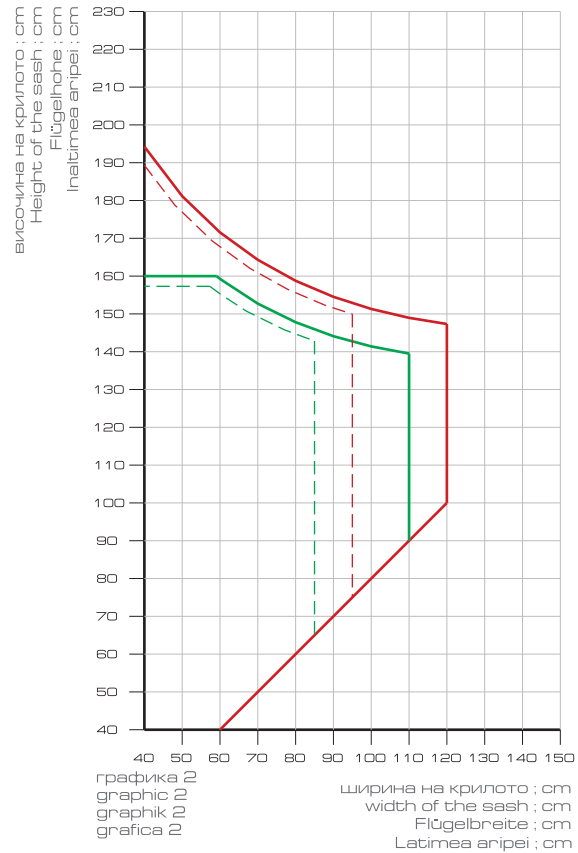
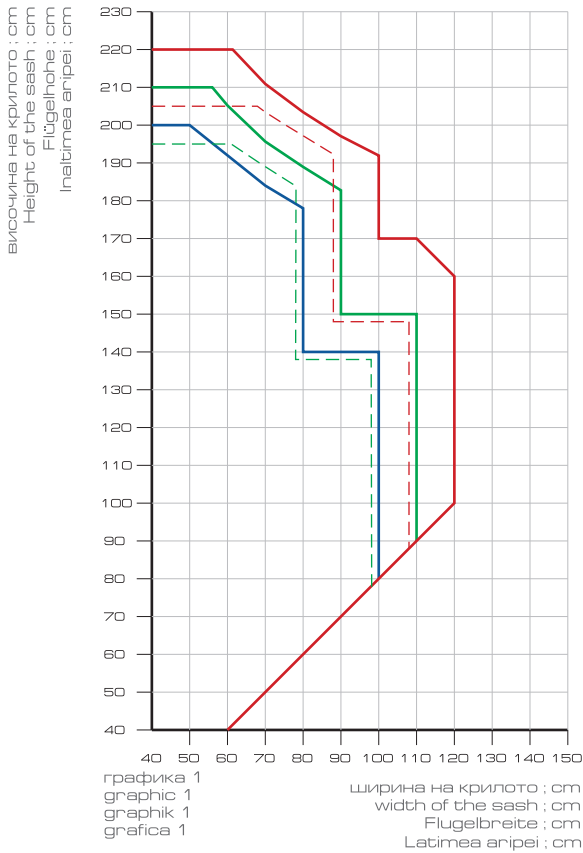

- VO8 / 2,0 mm /  $I_x = 1,51 \text{ cm}^4$  ;  $I_y = 3,53 \text{ cm}^4$
- VO8 / 1,5 mm /  $I_x = 1,22 \text{ cm}^4$  ;  $I_y = 2,80 \text{ cm}^4$
- VO8 / 1,2 mm /  $I_x = 1,02 \text{ cm}^4$  ;  $I_y = 2,32 \text{ cm}^4$

Изчисляване на необходимият инерционен момент  
 Calculation of the moment of inertia  
 Trägheitsmomentenberechnungsformel  
 Calcularea momentului inert necesar

$$I_n = \frac{W \cdot L^4 \cdot B/2}{1920 \cdot E \cdot f} \left[ 25 - 40 \left( \frac{B}{L} \right)^2 + 16 \left( \frac{B}{L} \right)^4 \right] ; \text{cm}^4$$

W - ветрово натоварване/ wind pressure/ Winddruck/  
 intensitatea vantului ; N/mm<sup>2</sup>

графика 1/graphic1/ graphik1  
 височина на сградата/height of the building/Gebäudehöhe/Înălțimea clădirii  
 0 ÷ 8 m - W = 600 Pa W = 0,0006 N/mm<sup>2</sup>

графика 2/graphic2 /graphik2  
 височина на сградата/ height of the building / Gebäudehöhe/Înălțimea clădirii  
 8 ÷ 20 m - W = 960 Pa W = 0,0096 N/mm<sup>2</sup>

графика 3/graphic3/graphik3  
 височина на сградата/height of the building/ Gebäudehöhe/Înălțimea clădirii  
 20 ÷ 100 m - W = 1320 Pa W = 0,00132 N/mm<sup>2</sup>

L - височина/ height/ Höhe/înălțime ; cm

B - ширина/ width/ Breite/latime ; cm

E - модул на еластичност/ elasticity module/ Elastizitätsmodul/  
 modulul elasticității (  $E_{cr} = 210 \text{ 000 N / mm}^2$  )

f - допустимо провисване/slack eligibility/zulässige Durchbiegung/  
 arcuinea admisa (  $f = L/300$  ;  $f \leq 0,8 \text{ cm}$  )

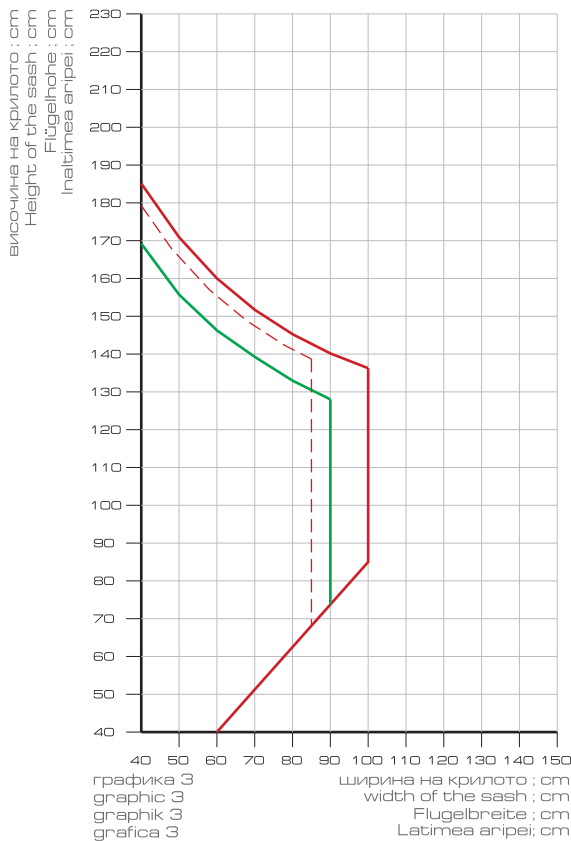

С прекъснатата линия са графициите за избор на усилен профил при ламиниран профил.  
 The graphics for choosing reinforced profiles for laminated profiles are with dotted line  
 Die gestrichene Linie kennzeichnet die benötigte Armierung bei laminiertem Profil.  
 Cu linia punctată sunt indicate graficele pentru alegerea armaturii pentru profilul laminat

# ОПРЕДЕЛЯНЕ НА НЕОБХОДИМИЯ ИНЕРЦИОНЕН МОМЕНТ

Calculation of the moment of inertia/ Traegheitsmomentberechnungsformel  
Calcularea momentului inert necesar

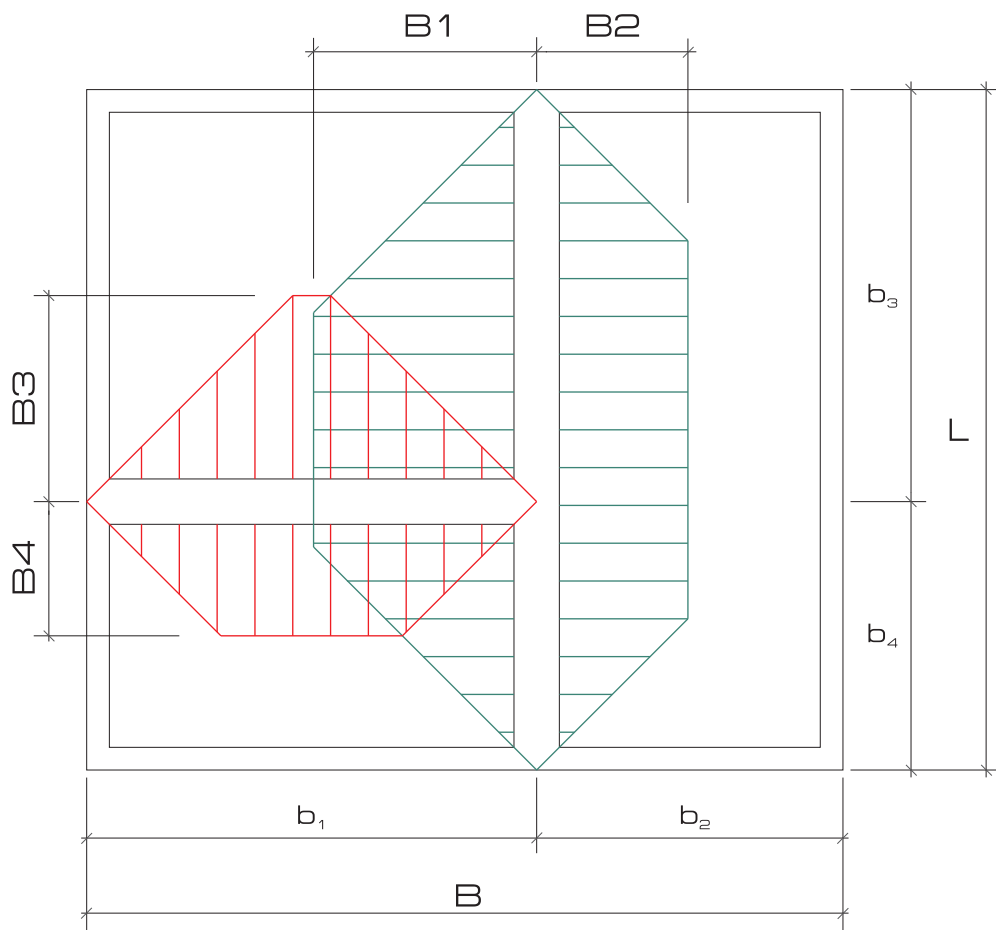

$$I_H = \frac{W \cdot L^4 \cdot B}{1920 \cdot E \cdot f} \left[ 25 - 40 \left( \frac{B}{L} \right)^2 + 16 \left( \frac{B}{L} \right)^4 \right] ; \text{cm}^4$$

W - ветрово натоварване/ wind pressure/Winddruck/intensitatea vantului ; N/mm<sup>2</sup>

височина на сградата/ height of the building/Gebaudehohe/ Inaltimea cladirii  
0 - 8 m - W = 600 Pa = 0,0006 N/mm<sup>2</sup>

височина на сградата/ height of the building/Gebaudehohe/ Inaltimea cladirii  
8 - 20 m - W = 960 Pa = 0,0096 N/mm<sup>2</sup>

височина на сградата/ height of the building/Gebaudehohe/ Inaltimea cladirii  
20 - 100 m - W = 1320 Pa = 0,00132 N/mm<sup>2</sup>

L - височина/ height/Hohe/ inaltime ; cm

B - ширина/ width/Breite/ latime ; cm      $B = b_x / 2$  ;      $b_x$  - ширина на клетката ; cm

E - модул на еластичност/ elasticity module/ Elastizitatsmodul/ modulul elasticitatii  
( E <sub>стопанна</sub> - 210 000 N / mm<sup>2</sup> )

E - модул на еластичност/ elasticity module/ Elastizitatsmodul/ modulul elasticitatii  
( E <sub>алуминий</sub> - 70 000 N / mm<sup>2</sup> )

f - допустимо провисване/ slack eligibility/zulassige Durchbiegung/ arcuirea admisa  
(  $f = L/300$  ;  $f \leq 0,8$  cm )

Прозорец с две крила с делител  
Zweiflügeliges Fenster mit Kaempfer  
Double open window with mullion  
Fereastra cu doua aripi cu traversa

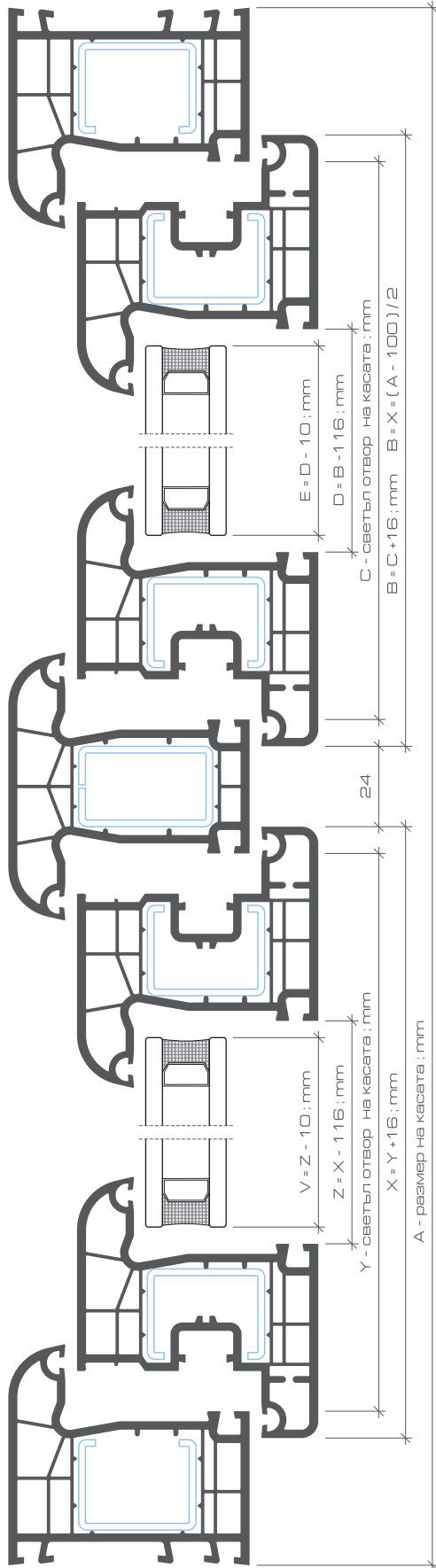

Прозорец с едно отваряемо крило  
Einflügeliges Fenster  
A single open window  
Fereastra cu o aripa deschisa

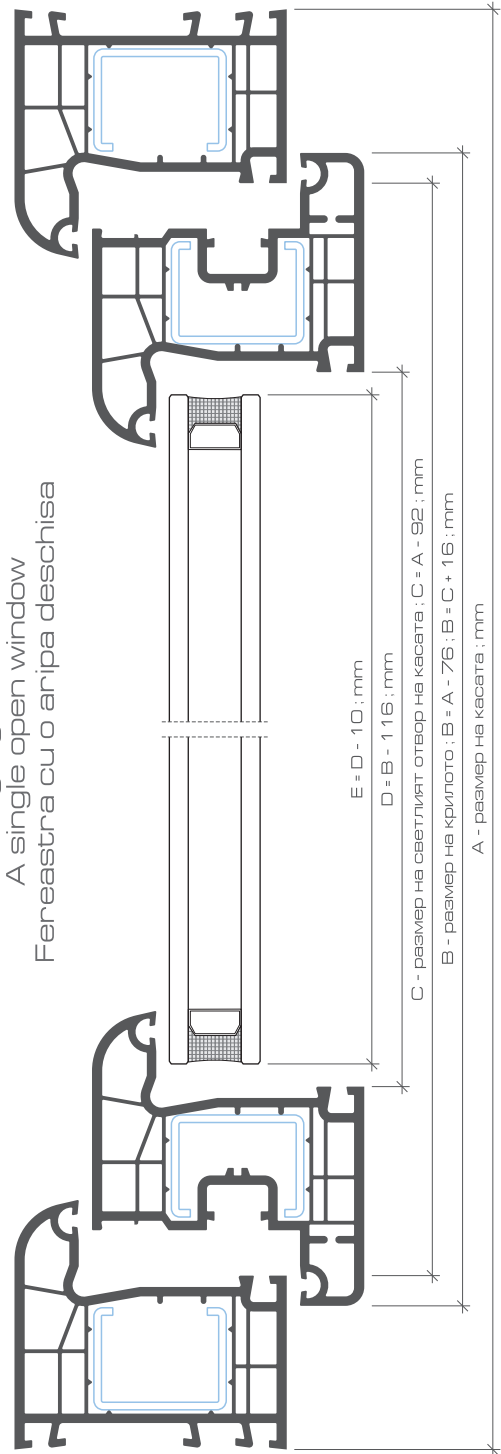

Прозорец с две крила с подвижен делител  
Zweiflügeliges Stulpfenster  
Double open window with a lap joint profile  
Fereastră cu două aripi cu inversor

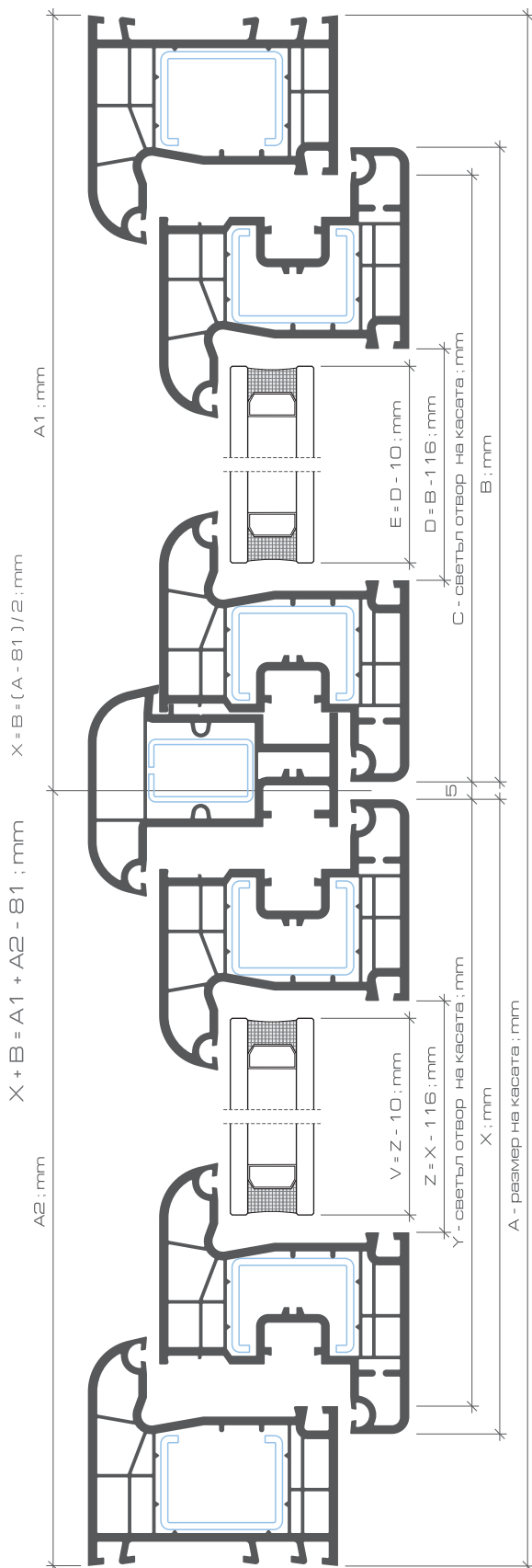

Врата с алуминиев праг  
Tür mit aluminium tuerschwelle  
Door with aluminium door - sill  
Usa cu prag de aluminiu

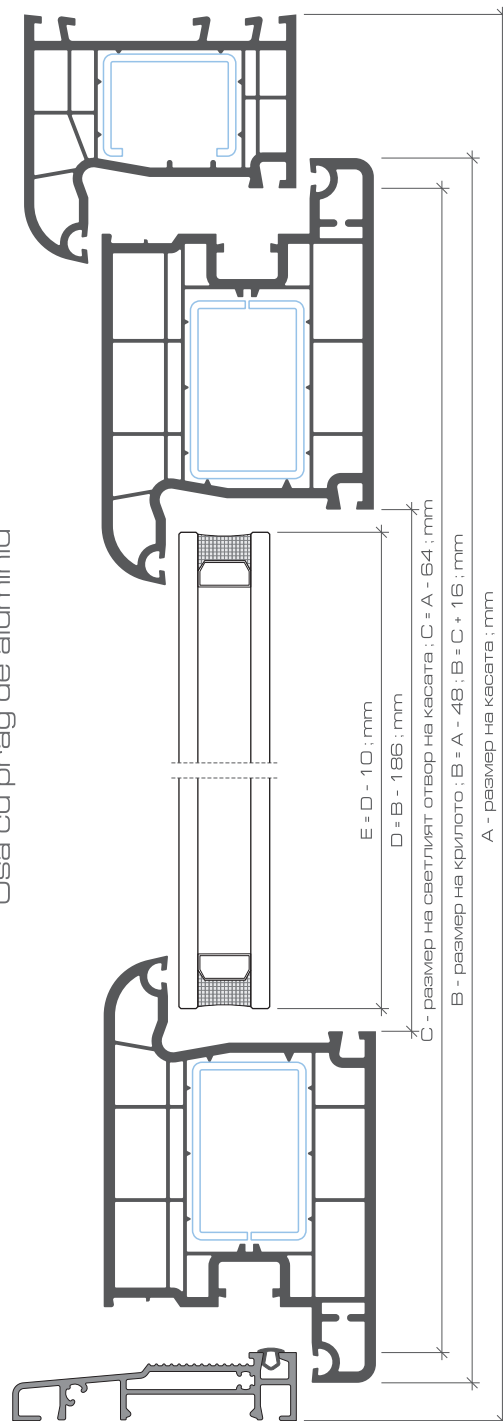



# ПРОФИЛИ С ЛАМИНИРАНО ПОКРИТИЕ / АРКИ

Bogen / Arches / Arcade Profile mit laminiertem Beschlag  
Profiles with polish cover  
Profile laminate



светъл орех  
nussbaum hell  
light walnut  
nuc deschis



тъмен орех  
nussbaum dunkel  
dark walnut  
nuc inchis

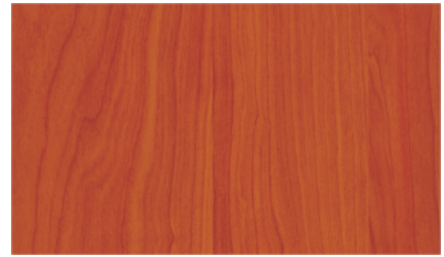

череша  
kirschbaum  
cherry  
cires



златен дъб  
goldeiche  
golden oak  
stejar auriu



тъмен дъб  
dunkeleiche  
dark oak  
stejar inchis

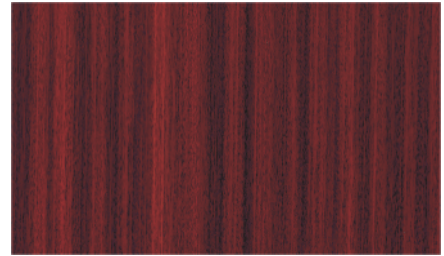

махагон  
mahagoni  
mahogany  
mahon

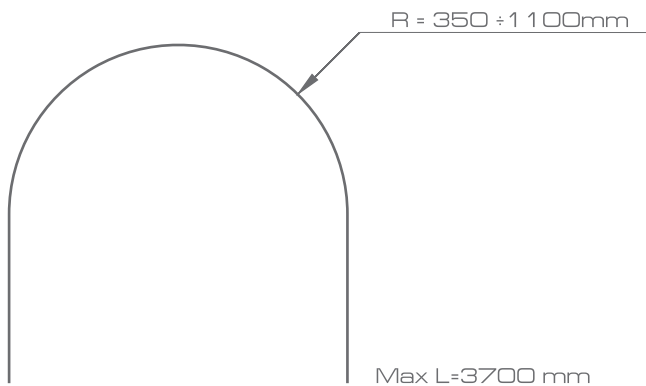
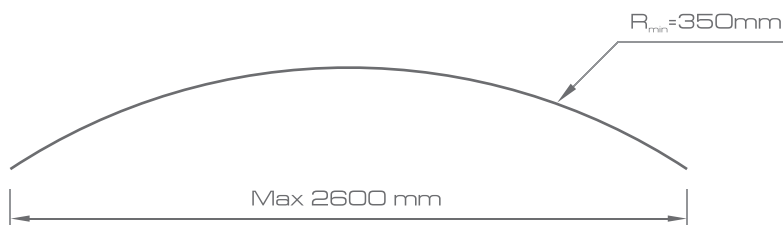

## Дъги:

Минимален радиус на дъгата: 350mm,  
максимален радиус: 2860mm.  
Максимална дължина на хордата: 2000mm.

## Bogen:

Min. Radius des Bogens: 350mm,  
max. Radius: 2860mm.  
Max. Länge der Sehne: 2000mm.

## Arcs:

Minimum radius of the arc: 350 mm,  
maximum radius: 2860mm.  
Maximum length of the chord: 2000mm.

## Arcade:

Raza minima a arcadei: 350mm,  
Raza maxima: 2860mm,  
Raza minima a arcadei: 2000mm

## Полукръжности:

Минимален радиус на полу-  
окръжността: 350mm,  
максимален радиус: 880mm.  
Максимална дължина на огъвката,  
заедно с двете вертикали: 3700mm.

## Halbkreise:

min. Radius des Halbkreises: 350mm,  
max. Radius: 880mm.  
Max. Länge der Biegung samt  
beiden Vertikalen: 3700 mm.

## Semicircles:

Minimum radius of the semicircle: 350mm,  
maximum radius: 880mm.  
Maximum length of the curve together  
with the two verticals: 3700mm.

## Semicircuri:

Raza minima a semicerculilor: 350mm,  
Raza maxima: 880mm,  
Lungimea maxima a arcadei impreuna  
cu cele doua verticale: 3700mm



A series of 25 horizontal dotted lines spanning the width of the page, intended for writing or drawing.



A series of horizontal dotted lines spanning the width of the page, intended for handwritten notes or text.

A series of horizontal dotted lines for writing, spanning most of the page width and arranged in a regular, repeating pattern.